

Honeywell

EC7830A, RM7830A, EC7850A, RM7850A 7800 SERIES Relay Modules

INSTALLATION INSTRUCTIONS

APPLICATION

The Honeywell EC/RM7830A and EC/RM7850A are microprocessor-based integrated burner controls for automatically fired gas, oil, or combination fuel single burner full modulation (EC/RM7850A) or on/off (EC/RM7830A) applications. The EC/RM7830A; EC/RM7850A system consists of a relay module, subbase, amplifier, and purge card. Options include keyboard display module (KDM), Data ControlBus™ Module and remote display mounting.

Functions provided by the EC/RM7830A and EC/RM7850A include automatic burner sequencing, flame supervision, system status indication, system or self-diagnostics and troubleshooting. Text readout on the Keyboard Display Module is available in various languages.

This document covers the following 7800 Series Relay Modules:

EC7830A1033
EC7830A1066
EC7850A1072
EC7850A1080
EC7850A1122
RM7830A1003
RM7830A1029
RM7850A1001
RM7850A1019
EC7830A2033
EC7830A2066
EC7850A2072
EC7850A2080
EC7850A2122
RM7830A2003
RM7830A2029
RM7850A2001
RM7850A2019

This document provides installation and static checkout instructions. Other applicable publications are:

Form Number	Description
32-00110	S7800A2142 4-line LCD Keyboard Display Module Product Data
32-00166	204729A/C KDM NEMA4 Covers for 4-line LCD KDM
32-00235	R7824, R7847, R7848, R7849, R7861, R7886 Flame Amplifiers for the 7800 SERIES Product Data
65-0084	Q7800A,B 22-Terminal Wiring Subbase Product Data
65-0090	S7800A Keyboard Display Module Product Data
65-0091	S7810A Data ControlBus™ Module Product Data
65-0095	S7820 Remote Reset Module Product Data
65-0097	221729C Dust Cover Packing Instructions
65-0131	221818A Extension Cable Assembly Product Data
65-0228	S7810B Multi-Drop Switch Module Product Data
65-0229	7800 SERIES Relay Modules Checkout and Troubleshooting Product Data
65-0249	S7810M ModBus Module (For CE , Modbus module S7810M1029 only).
65-0295	50023821-001/2 KDM NEMA4 Covers for classic 2-line VFD KDM



SPECIFICATIONS

Electrical Ratings (See Tables 3A, 3B, 3C and 3D):

Voltage and Frequency:

RM7830A and RM7850A:

120 Vac (+10/-15%), 50/60 Hz (±10%).

EC7830A and EC7850A:

220/240 Vac (+10%/-15%), 50/60 Hz (±10%)

Power Dissipation: 10W maximum.

Maximum Total Connected Load: 2000 VA.

Fusing Total Connected Load: 15A maximum, Fast Blow, type SC or equivalent.

Environmental Ratings:

Ambient Temperature:

Operating: -40°F to 140°F (-40°C to +60°C).

Storage: -40°F to 150°F (-40°C to +66°C).

Humidity: 85% relative humidity continuous, noncondensing.

Vibration: 0.5G environment.

SIL 3 Capable:

SIL 3 Capable in a properly designed Safety Instrumented System. See form 65-0312 for Certificate Agreement

Approvals

Federal Communications Commission:

Part 15, Class B, Emissions.

Exida: IEC/EN 61508:2010 Parts 1-7, SIL 3 capable.

AGA Certificate # 5097

EAC Russia

Factory Mutual Approved: Report No. 1V9A0.AF (for RM7830A1003, RM7830A1029, RM7850A1001, RM7850A1019, RM7830A2003, RM7830A2029, RM7850A2001, RM7850A2019)

European Directives

Gas Appliances Regulation: 2016/426/EU GAR

Low Voltage Directive: 2014/35/EU LVD.

EMC Directive: 2014/30/EU EMC (Immunity Emission conformity can only be verified in combination with the appliance).

GASTEC: certificate # 18GR0996/00, PIN 0063CT1466

Applicable Standards:

EN 298:2012 Automatic burner controls

EN 60335-2-102 Household and similar electrical appliances

EN 746-2 Industrial thermo-processing - fuel handling systems

Please note the following to comply with EN60730 for remote mounting of the KDM and/or remote reset module. It is necessary to provide electrical separation using insulation at least equivalent to double or reinforced insulation. This can be accomplished by either:

1. Optically isolating the communication and/or remote reset lines from the control cabinet or
2. Providing physical separation from the communication and/or remote reset lines using electrical conduit and a 204718A Remote Display Cover Assembly or other suitable enclosure that meets NEMA4 class of protection.

INSTALLATION

When Installing this Product...

1. Read these instructions carefully. Failure to follow them could damage the product or cause a hazardous condition.
2. Check the ratings given in the instructions and marked on the product to make sure the product is suitable for the application.
3. Installer must be a trained, experienced, flame safeguard service technician.
4. After installation is complete, check out the product operation as provided in these instructions.



WARNING

Fire or Explosion Hazard.

Can cause severe injury, death or property damage.

Carefully follow safety requirements when installing a burner control.



WARNING

Electrical Shock Hazard or Equipment Damage Hazard.

Can cause severe injury, death or equipment damage.

Disconnect power supply before beginning installation. More than one disconnect may be involved.

Continuous Operation Note

Non-check amplifiers cannot be used in continuous operation (per EN298). For continuous operation only ampli-check or shutter/self-check flame amplifiers are used.

Non-check amplifiers trigger the device to automatically recycle after 24 hours when in a continuous run mode.

IMPORTANT

1. *Wiring connections for the relay modules are unique; refer to Fig. 4 and 5 or the appropriate Specifications for individual subbase wiring.*
2. *Wiring must comply with all applicable codes, ordinances and regulations.*
3. *Wiring must comply with NEC Class 1 (Line Voltage) wiring.*
4. *Loads connected to the EC/RM7830A and EC/RM7850A must not exceed those listed on the relay module label or the Specifications; see Table 1.*
5. *Limits and interlocks must be rated to simultaneously carry and break current to the ignition transformer, pilot valve, and main fuel valve(s).*
6. *All external timers must be listed or component-recognized by authorities who have proper jurisdiction.*
7. *For on-off gas-fired systems, some authorities who have jurisdiction prohibit the wiring of any limit or operating contacts in series between the flame safeguard control and the main fuel valve(s).*

8. Two flame detectors can be connected in parallel with the exception of C7915 Infrared Flame Detectors, C7927 or C7961 Ultraviolet Flame Detectors and C7962 Visible Light Detector.
9. *This equipment generates, uses and can radiate radio frequency energy and, if not installed and used in accordance with the instructions, can cause interference with radio communications. It has been tested and found to comply with the limits for a Class B computing device of Part 15 of FCC rules, which are designed to provide reasonable protection against such interference when operated in a commercial environment. Operation of this equipment in a residential area can cause interference, in which case, the users, at their own expense, may be required to take whatever measures are required to correct this interference.*
10. *This digital apparatus does not exceed the Class B limits for radio noise for digital apparatus set out in the Radio Interference Regulations of the Canadian Department of Communications.*

Location

Humidity

Install the relay module where the relative humidity never reaches the saturation point. The relay module is designed to operate in a maximum 85% relative humidity continuous, noncondensing, moisture environment. Condensing moisture can cause a safety shutdown.

Vibration

Do not install the relay module where it can be subjected to vibration in excess of 0.5G continuous maximum vibration.

Weather

The relay module is not designed to be weather tight. When installed outdoors, protect the relay module in an approved weather-tight enclosure.

Mounting of Remote Keyboard or Reset Module

To comply with CE EN60730 for remote mounting of the KDM and/or Remote Reset Module it is necessary to provide electrical separation using insulation at least equivalent to double or reinforced insulation.

This can be accomplished by either:

1. Optically isolating the communication and/or remote reset lines from the control cabinet.
2. Providing physical separation from the communication and/or remote reset lines using electrical conduit and a 204718A Remote Display Cover Assembly or other suitable enclosure that meets NEMA 4 class of protection.

Mounting Wiring Subbase

1. Mount the subbase in any position except horizontally with the bifurcated contacts pointing down. The standard vertical position is recommended. Any other position decreases the maximum ambient temperature rating.
2. Select a location on a wall, burner or in an electrical panel (required for all European devices). The Q7800 can be mounted directly in the control cabinet. Be sure to allow adequate clearance for service, installation, access or removal of the 7800 SERIES Relay Module, KDM, flame amplifier, flame amplifier signal voltage probes, Run/Test Switch, electrical signal voltage probes and electrical field connections.
3. For surface mounting, use the back of the subbase as a template to mark the four screw locations, then drill the pilot holes.
4. Securely mount the subbase using four no. 6 screws (not provided).

NOTE: You might receive an error code 101 (via KDM) if one of the following conditions exist:

- a. The screws securing the relay to the subbase are not tight enough, re-tighten to insure there is no gap between the relay and the subbase.
- b. If you attempt to place a 2000 series relay on a non-compatible 1000 series subbase, this indicates that you must:
 - Change out the subbase to a Q7800A2003/U or Q7800A2005/U
 - Choose a compatible 1000 series relay module

Relay Module and Subbase Compatibility

NOTE: There are several different subbase models that can be purchased. It is important to note which subbase is compatible with the relay module when purchasing new, repair or replacement parts.

Series 1000 Relay Modules

All relay product codes that start with a 1 (example: RM7830G1003/U) can be used with existing subbase Q7800A1003/U and Q7800A1005/U.

Series 2000 Relay Modules

All relay product codes that start with a 2 (example: RM7840G2004/U) must be used with subbase Q7800A2003/U and Q7800A2005/U.

Subbase Compatibility

Any Relay Module in the 1000 Series with a Software Revision level number starting with a "5" or greater will be compatible with all subbase models both installed and newly purchased. This includes (Q7800A1005/U, Q7800B1003/U), and the 2000 Series subbases (Q7800A2005/U, Q7800B2003/U).

See Fig. 1 for Software Revision Level number location on the label (located on the rear of the relay module).

Any relay module in the new 2000 series will only be able to be installed on subbase Q7800A2005/U, Q7800B2003/U and will not be backward compatible with any Q7800A1003/U and Q7800A1005/U subbases already installed in the field.



Fig. 1. Software revision location.

IMPORTANT

Make sure to check the relay model number and the software revision level on the relay.

5. If you attempt to place a 2000 series relay on a non-compatible 1000 series subbase, you will receive an error code of 101. This indicates that you must a) change out the subbase to a Q7800A2003/U or Q7800A2005/U or b) choose a compatible 1000 series relay module

Wiring Subbase

⚠ WARNING

Electrical Shock Hazard or Equipment Damage Hazard.

Can cause sever injury, death or equipment damage.

Disconnect the power supply before beginning installation. More than one disconnect may be involved.

The internal block diagram of the EC/RM7830A is shown in Fig. 2 and the internal block diagram of the EC/RM7850A is shown in Fig. 3.

1. For subbase wiring and sequence charts, refer to Fig. 3 and 4.
2. For proper remote wiring of the KDM, refer to the Specifications for the 2-line VFD KDM (65-0090), the 4-line LCD KDM (32-00110), Data ControlBus Module™ (65-0091) or Extension Cable Assembly (65-0131).

3. Disconnect the power supply from the main disconnect before beginning installation to prevent electrical shock and equipment damage. More than one disconnect can be required.
4. All wiring must comply with all applicable electrical codes, ordinances and regulations. Wiring, where required, must comply with NEC Class 1 (Line Voltage) wiring.
5. For recommended wire size and type, see Table 1.
6. Recommended wire routing of leadwires:
 - a. Do not run high voltage ignition transformer wires in the same conduit with the flame detector, Data ControlBus™ Module, or Remote Reset Module wiring.
 - b. Do not route flame detector, Data ControlBus™ Module, or Remote Reset Module leadwires in conduit with line voltage circuits.
 - c. Enclose flame detector leadwires without armor cable in metal cable or conduit.
 - d. Follow directions in flame detector, Data ControlBus™ Module, or Remote Reset Module Instructions.
7. For recommended grounding practices, see Table 2.
8. The KDM is powered from a low voltage, energy limited source. Mount the KDM outside of a control panel when it is protected from mechanical damage.

IMPORTANT

A 13 Vdc power supply must be used any time more than one KDM is used. A maximum of two KDM, Data ControlBus™ Modules or S7810B Multi-Drop Switch Modules are allowed in any combination.

9. Maximum wire lengths:
 - a. EC/RM7830A and EC/RM7850A leadwires: The maximum leadwire length is 300 feet (91 meters) to terminal inputs (Control, Running/Lockout Interlock).
 - b. Flame Detector leadwires: The maximum flame sensor leadwire length is limited by the flame signal strength.
 - c. Remote Reset leadwires: The maximum length of wire is 1000 feet (305 meters) to a Remote Reset pushbutton.
 - d. Data ControlBus™ Module: The maximum Data ControlBus™ Module cable length depends on the number of system modules connected, the noise conditions and the cable used. The maximum length of all Data ControlBus™ Module interconnecting wire is 4000 feet (1219 meters).
10. Be sure loads do not exceed the terminal ratings. Refer to the label on the relay module or to the terminal ratings in Tables 3A, 3B, 3C and 3D.

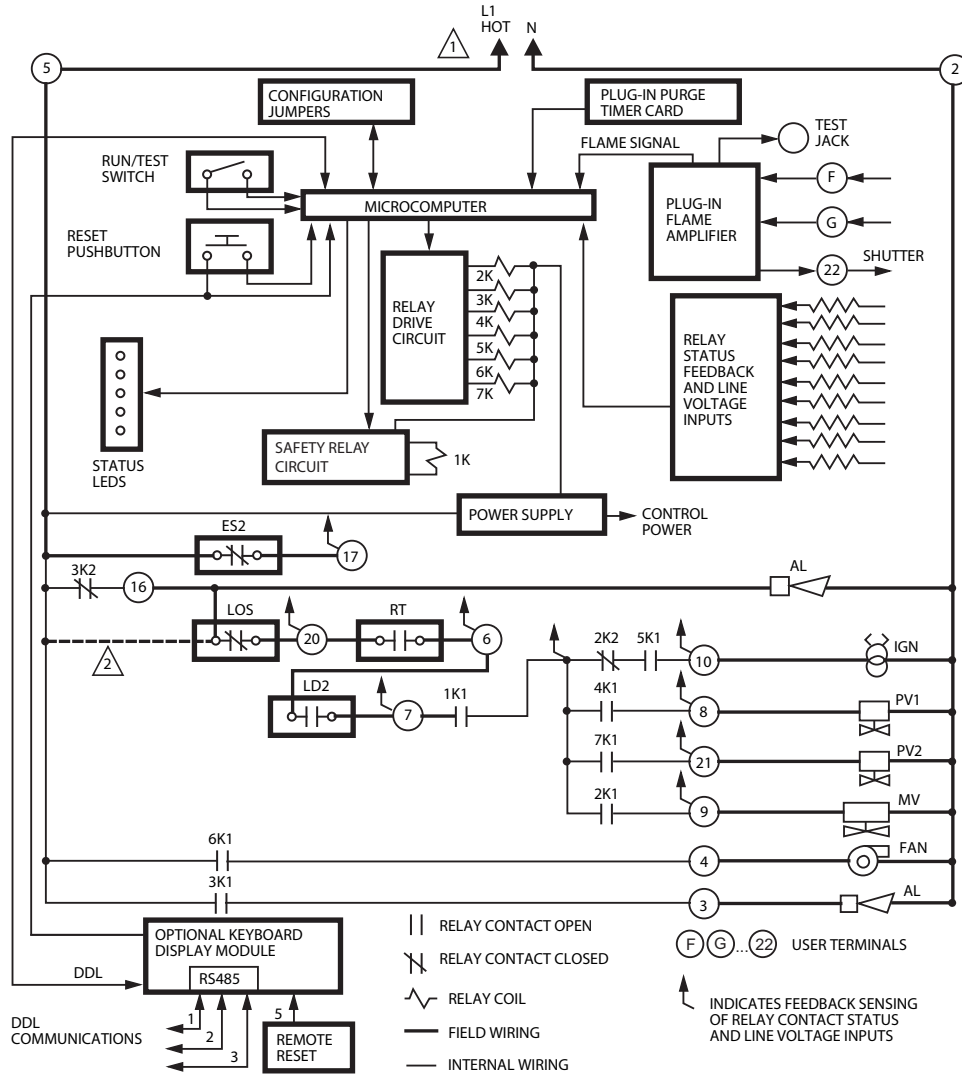

- 1 120 VAC, 50/60 Hz POWER SUPPLY, RM7830A; 220-240 VAC, 50/60 Hz POWER SUPPLY, EC7830A. PROVIDE DISCONNECT MEANS AND OVERLOAD PROTECTION AS REQUIRED.
- 2 TO CONNECT L1 DIRECTLY TO LOS, AT LEAST ONE CONTROLLED SHUTDOWN MUST BE PROVIDED EVERY 24 HOURS.

M15183B

Fig. 2. Internal block diagram of EC/RM7830A (see Fig. 4 for detailed wiring instructions).

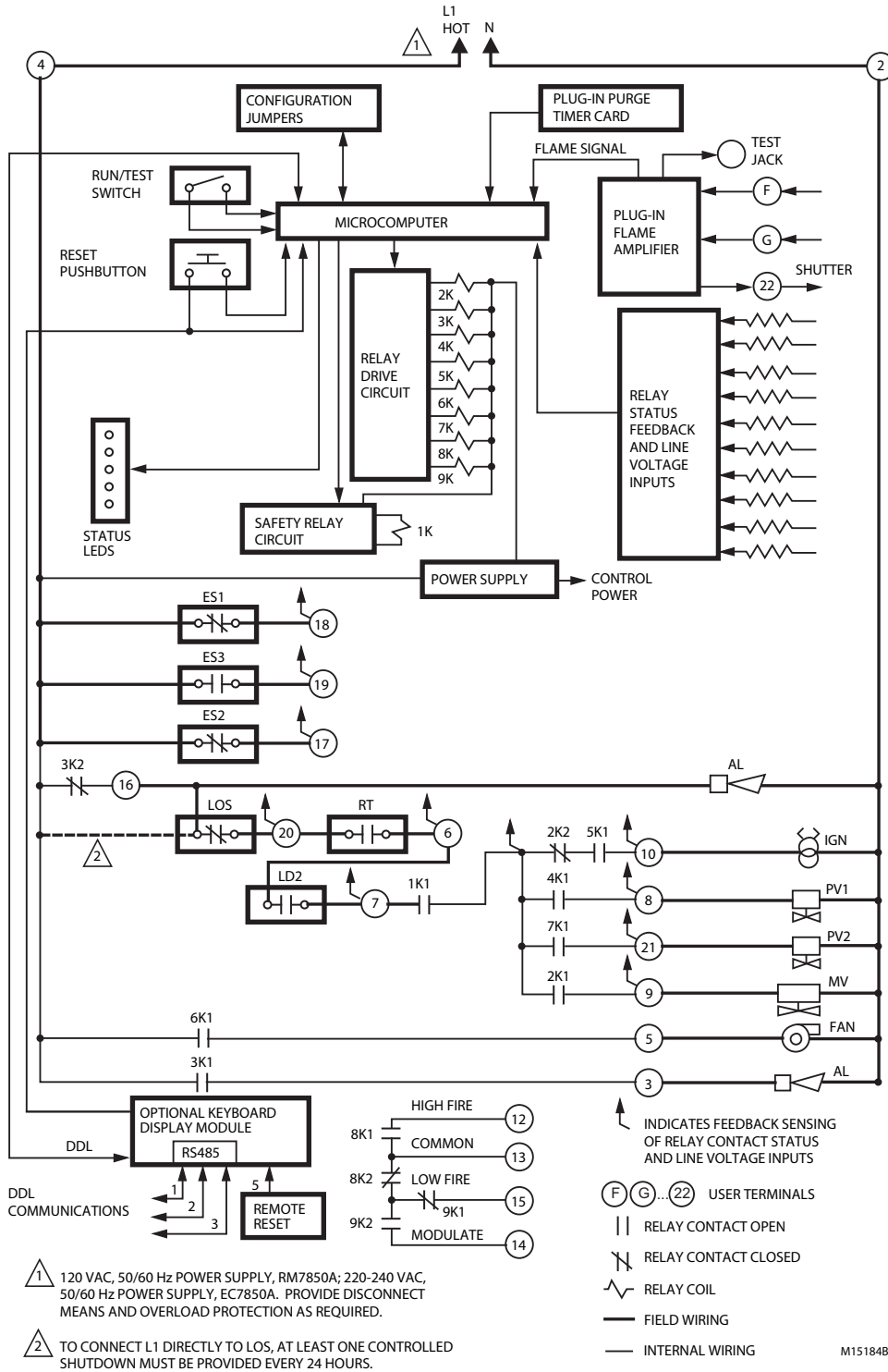
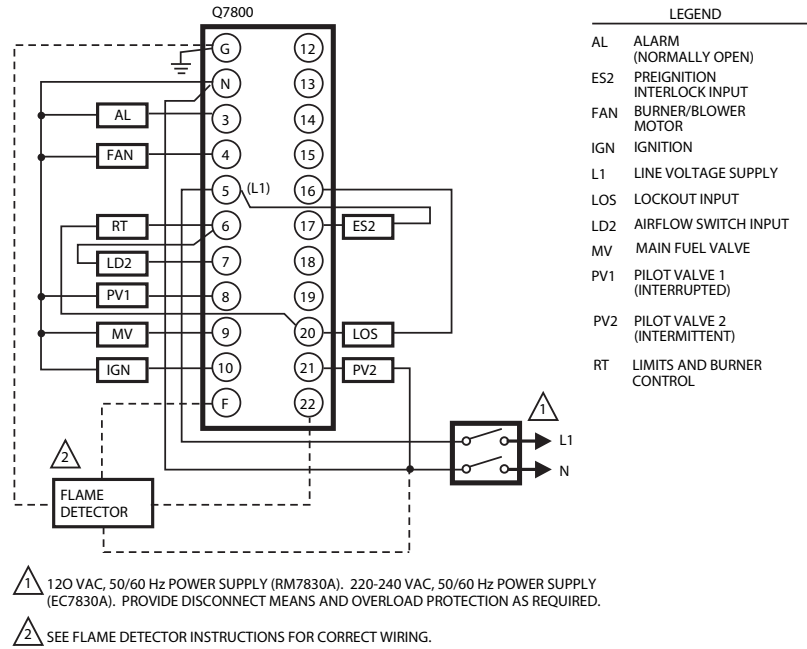

Fig. 3. Internal block diagram of EC/RM7850A (see Fig. 5 for detailed wiring instructions).



EC/RM7830A Power Burner ON/OFF, GAS or OIL Sequence

LED DISPLAY	INITIATE	STANDBY	"PREPURGE" WAITING	PRE IGNITION	FIRST SAFETY TIME	PILOT STABIL.	MAIN TRIAL TIME	MAIN STABIL.	RUN	POSTPURGE	STANDBY
POWER	●	●	●	●	●	●	●	●	●	●	●
PILOT	○	○	○	○	●	●	●	○	○	○	○
FLAME	○	○	○	○	●	●	●	●	●	○	○
MAIN	○	○	○	○	○	○	●	●	●	○	○
ALARM	○	○	○	○	○	○	○	○	○	○	○
BURNER			BURNER/BLOWER MOTOR (4)								
				IGNITION (10)							
					PILOT VALVE (8)						
						V2 (21)					
							MAIN VALVE (9)				
OPERATING CONTROLS AND INTERLOCKS			PREIGNITION INTERLOCK (17)								
				LIMITS AND BURNER CONTROL CLOSED (6)							
				LOCKOUT INPUT (20)							
			10 sec		AFS CHK						AFS CHK
				AIRFLOW SWITCH CHECK (7)							
FLAME SIGNAL			SAFE START CHECK			FLAME PROVING				SAFE START CHECK	
OPTIONS	2 sec	AFS CHK									
			3 sec	3 or 5 sec	5 sec	3 or 5 sec	5 sec			2, 15 or 30 sec	

IF ON AT CALL FOR HEAT, HOLD (120 sec). LOCK OUT IF STILL ON.
 IF OFF AFTER 10 SEC OF FAN, LOCK OUT.
 TAKE LOCKOUT ACTION, CONTINUE POSTPURGE TIMING.

SELECT VIA ST7800A PURGE TIMER CARD.
 DUE TO ONE EXTRA SECOND FOR SAFETY RELAY TEST, TIMING CAN VARY FROM 3 TO 4 SECONDS.
 SELECT VIA CONFIGURATION JUMPERS OR MODEL NUMBERS.

Fig. 4. Wiring subbase and sequence chart for EC/RM7830A.

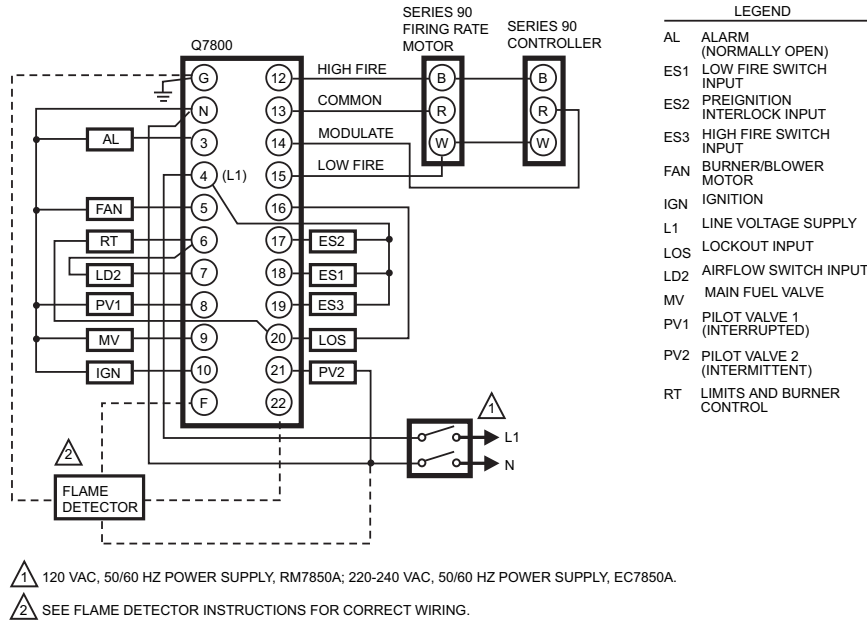

EC/RM7850A Power Burner Full Modulation, GAS or OIL Sequence

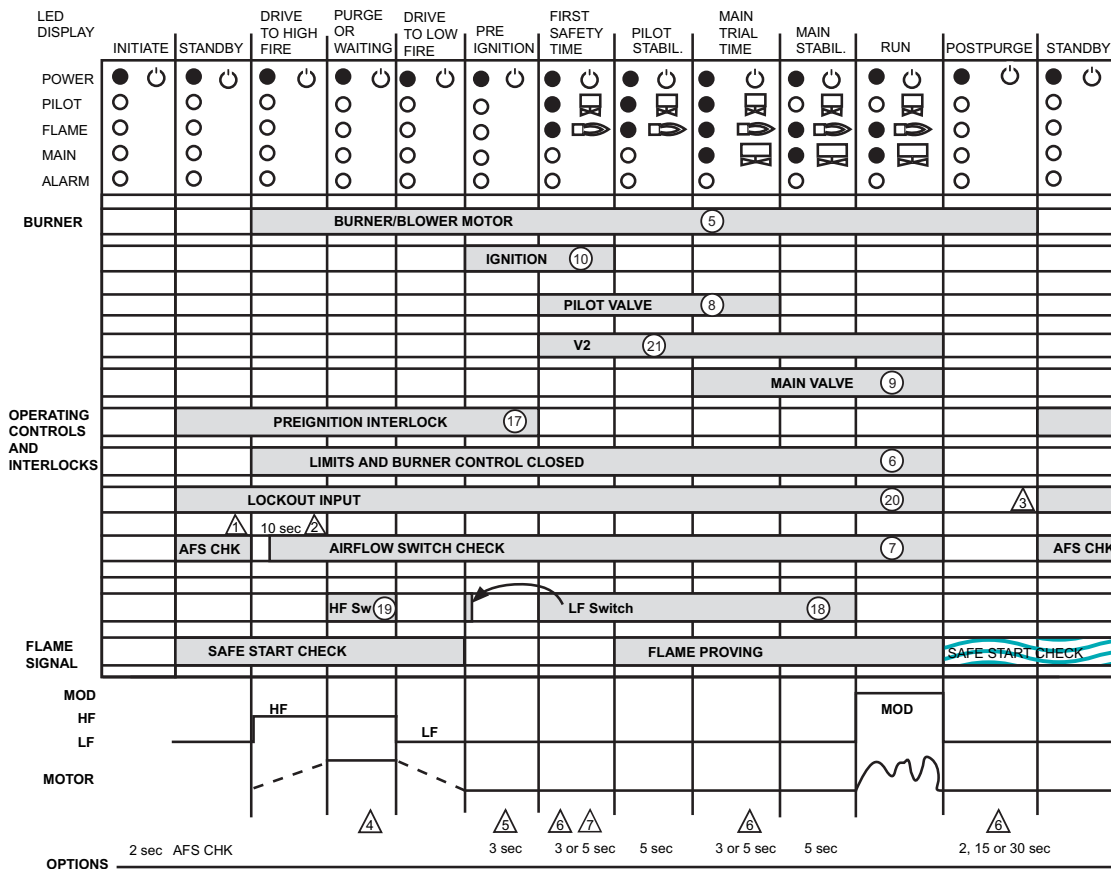

- ⚠ IF ON AT CALL FOR HEAT, HOLD (120 SEC). LOCK OUT IF STILL ON.
- ⚠ IF OFF AFTER 10 SEC OF FAN, LOCK OUT.
- ⚠ TAKE LOCKOUT ACTION. CONTINUE POSTPURGE TIMING.
- ⚠ SELECT VIA ST7800A PURGE TIMER CARD.
- ⚠ DUE TO ONE EXTRA SECOND FOR SAFETY RELAY TEST, TIMING CAN VARY FROM 3 TO 4 SEC.
- ⚠ SELECTION VIA CONFIGURATION JUMPERS OR MODEL NUMBERS.
- ⚠ EC7850A1148/RM7850A1035 IS 3 OR 2 SELECTED VIA CONFIGURATION JUMPER.

M23304

Fig. 5. Wiring subbase and sequence chart for EC/RM7850A.

Table 1. Recommended Wire Sizes and Part Numbers.

Application	Recommended Wire Size	Recommended Part Numbers
Line Voltage Terminals	14, 16, or 18 AWG (0.75, 1.5 or 2.5 mm ²) copper conductor, 600 volt insulation, moisture-resistant wire.	TTW60C, THW75C, THHN90C.
Keyboard Display Module KDM ^a	22 AWG (0.34 mm ²) two-wire twisted pair with ground, or five-wire.	Belden 8723 shielded cable or equivalent.
Data ControlBus™ Module		
Remote Reset Module	22 AWG (0.34 mm ²) two-wire twisted pair, insulated for low voltage.	—
Communications Interface ControlBus™ Module	22 AWG (0.34 mm ²) two-wire twisted pair with ground.	Belden 8723 shielded cable or equivalent.
13 Vdc full wave rectified transformer power input	18 AWG (0.75 mm ²) wire insulated for voltages and temperatures for given application.	TTW60C, THW75C, THHN90C.

^a The KDM, Data ControlBus™ Module (for remote mounting or communications) or Communication Interface ControlBus™ Module must be wired in a daisy chain configuration, (1(a)-1(a), 2(b)-2(b), 3(c)-3(c)). The order of interconnection of all the devices listed above is not important. Be aware that modules on the closest and farthest end of the daisy chain configuration string require a 120 ohm (1/4 watt minimum) resistor termination across terminals 1 and 2 of the electrical connectors for connections over 100 feet (30.5 meters).

Table 2. Recommended Grounding Practices.

Ground Type	Recommended Practice
Earth ground (subbase and relay module)	<ol style="list-style-type: none"> 1. Use to provide a connection between the subbase and the control panel of the equipment. Earth ground must be capable of conducting enough current to blow the 15A fuse (or breaker) in the event of an internal short circuit. 2. Use wide straps or brackets to provide minimum-length, maximum-surface area ground conductors. If a leadwire must be used, use 14 AWG (2.5 mm²) copper wire. 3. Make sure that mechanically tightened joints along the ground path are free of nonconductive coatings and protected against corrosion on mating surfaces.
Signal Ground (KDM, Data ControlBus™ Module, Communications Interface ControlBus™ Module)	Use the shield of the signal wire to ground the device to the signal ground terminal 3(c) of each device. Connect the shield at both ends of the daisy chain to earth ground.

Final Wiring Check

1. Check the power supply circuit. The voltage and frequency tolerance must match those of the relay module. (A separate power supply circuit can be required for the relay module.) Add the required disconnect means and overload protection.
2. Check all wiring circuits and complete the Static Checkout in Table 5 or 6 before installing the relay module on the subbase.
3. Install the relay module.
4. Restore power to the panel.

Mounting EC/RM7830A; EC/RM7850A Relay Module

1. Mount the relay module vertically on the Q7800 Subbase, or mount horizontally with the knife blade terminals pointing down. Select a location on a wall, burner or electrical panel to mount the subbase. For all CE device installations the subbase must be mounted inside of an approved electrical cabinet where access is restricted.
2. Be sure to allow adequate clearance for servicing, installation and removal of the relay module, KDM, flame amplifier, flame amplifier signal voltage probes, electrical signal voltage probes and electrical connections.
 - a. Allow an additional 2 in. (51 mm) below the relay module for the flame amplifier mounting.
 - b. Allow an optional 3 in. (76 mm) minimum on both sides of the relay module for electrical signal voltage probes.

3. Make sure no subbase wiring is projecting beyond the terminal blocks. Tuck in wiring against the back of the subbase so it does not interfere with the knife blade terminals or bifurcated contacts.

IMPORTANT

Install the relay module with a plug-in motion rather than a hinge action.

4. Mount the relay module by aligning the four L shaped corner guides and knife blade terminals with the bifurcated contacts on the wiring subbase and securely tightening the two screws without deforming the plastic.

STATIC CHECKOUT

After checking all wiring, perform this checkout before installing the relay module on the wiring subbase. These tests verify that the Q7800 Wiring Subbase is wired correctly and the external controllers, limits, interlocks, actuators, valves, transformers, motors and other devices are operating properly.

For further checkout and troubleshooting, see form 65-0229.

Table 3. EC7830A/RM7830A Terminal Ratings.

Terminal No.	Abbreviation	Description	Ratings	
			RM7830A (120 Vac)	EC7830A (220/230/240 Vac)
G	—	Flame Sensor Ground ^a	—	—
Earth G	—	Earth Ground ^a	—	—
N	—	Line Voltage Common (Neutral)	—	—
3	AL	Alarm (Normally Open)	1A, 10A inrush for 5000 cycles.	1A, 10A inrush for 5000 cycles.
4	FAN	Burner/Blower Motor	4A at PF = 0.5, 20A inrush. ^b	4A at PF = 0.5, 20A inrush.
5	L1	Line Voltage Supply (L1)	120 Vac(+10%/-15%), 50/60 Hz (±10%). ^c	220 to 240 Vac (+10%/-15%), 50/60 Hz (±10%). ^c
6	RT	Limits and Burner Control	1 mA	1 mA maximum
7	LD2	Airflow Switch Input	5A.	5A.
8	PV1	Pilot Valve 1 (Interrupted)	4A at PF = 0.5, 20A inrush.	4A at PF = 0.5, 20A inrush.
9	MV	Main Fuel Valve	4A at PF = 0.5, 20A inrush.	4A at PF = 0.5, 20A inrush.
10	IGN	Ignition	2A at PF = 0.2.	2A at PF = 0.2.
F (11)	—	Flame Signal	60 to 220 Vac, current limited.	60 to 220 Vac, current limited.
12 to 15	Not Used.			
16	—	Control Voltage	120 Vac (+10%/-15%). ^d	220 to 240 Vac (+10%/-15%). ^d
17	ES2	Preignition Interlock Input	1 mA.	1 mA. ^d
18 to 19	Not Used.			
20	LOS	Lockout Input.	1 mA.	1 mA.
21	PV2	Pilot Valve 2 (intermittent)	4A at PF = 0.5, 20A inrush.	4A at PF = 0.5, 20A inrush.
22	SHTR	Shutter	Shutter drive for dynamic self-check flame sensor.	Shutter drive for dynamic self-check flame sensor. ^e

^a See Table 2.

^b Honeywell has tested this output at 9.8A at PF = 0.5, 58.8A inrush for 100,000 cycles (EN298 approval does not require this test).

^c 2000 VA maximum connected load to relay module.

^d 1A, 10A inrush for 5000 cycles; carry 5A for 250,000 cycles.

^e 220/240 Vac to 120 Vac, 10 VA stepdown transformer (not provided) must be used to drive the shutter. Transformer does not apply to UV flame sensor models C7061A1020, C7061A1079 and C7061F1003 (combined with R7861-series flame amplifiers), which have internal selectable terminal block to connect 230V shutter output directly.

Table 4. EC7850A/RM7850A Terminal Ratings.

Terminal No.	Abbreviation	Description	RM7850A (120 Vac)	EC7850A (220/230/240 Vac)
G	—	Flame Sensor Ground. ^a	—	—
Earth G	—	Earth Ground. ^a	—	—
N	—	Line Voltage Common (Neutral)	—	—
3	AL	Alarm (Normally Open)	1A, 10A inrush for 5000 cycles.	1A, 10A inrush for 5000 cycles.
4	L1	Line Voltage Supply (L1)	120 Vac (+10%/-15%), 50/60 Hz (±10%). ^b	220/230/240 Vac (+10%/-15%), 50/60 Hz (±10%). ^b
5	FAN	Burner/Blower Motor	4A at PF = 0.5, 20A inrush. ^c	4A at PF = 0.5, 20A inrush.
6	RT	Limits and Burner Control	1 mA.	1 mA.
7	LD2	Airflow Switch Input	5A.	5A.
8	PV1	Pilot Valve 1 (Interrupted)	4A at PF = 0.5, 20A inrush. ^d	4A at PF = 0.5, 20A inrush. ^e
9	MV	Main Fuel Valve	4A at PF = 0.5, 20A inrush. ^d	4A at PF = 0.5, 20A inrush. ^e
10	IGN	Ignition	2A at PF = 0.2.	2A at PF = 0.2.
F(11)	—	Flame Signal	60 to 220 Vac, current limited.	136 to 220 Vac, current limited.
12	HI	Firing Rate High Fire	0.5A at PF = 0.5. ^f	0.5A at PF = 0.5. ^f
13	COM	Firing Rate Common	0.5A at PF = 0.5. ^g	0.5A at PF = 0.5. ^f
14	MOD	Firing Rate Modulate	0.5A at PF = 0.5. ^f	0.5A at PF = 0.5. ^f
15	LO	Firing Rate Low Fire	0.5A at PF = 0.5. ^f	0.5A at PF = 0.5. ^f
16	—	Alarm (Normally Closed)	1A, 10A inrush for 5000 cycles; carry 5A for 250,000 cycles.	1A, 10A inrush for 5000 cycles; carry 5A for 250,000 cycles.
17	ES2	Preignition Interlock Input	1 mA.	1 mA.
18	ES1	Low Fire Switch Input	1 mA.	1 mA.
19	ES3	High Fire Switch Input	1 mA.	1 mA.
20	LOS	Lockout Input	1 mA.	1 mA.
21	PV2	Pilot Valve 2 (Intermittent)	4A at PF = 0.5, 20A inrush. ^d	4A at PF = 0.5, 20A inrush. ^e
22	SHTR	Shutter	Shutter drive for dynamic self-check flame sensor.	Shutter drive for dynamic self-check flame sensor. ^g

^a See Table 2.

^b 2000 VA maximum connected load to relay module.

^c Honeywell has tested this output at 9.8A at PF = 0.5, 58.8A inrush for 100,000 cycles (EN298 approval does not require this test).

^d Total load current, excluding Burner/Boiler Motor and Firing Rate Outputs cannot exceed 5A, 25A inrush.

^e Total load current, excluding Burner/Boiler Motor and Firing Rate Outputs cannot exceed 5A, 25A inrush for 250,000 cycles.

^f Can also be 24 Vac, 3A at PF = 0.5.

^g Transformer does not apply to UV flame sensor models C7061A1020, C7061A1079 and C7061F1003 (combined with R7861-series flame amplifiers), which have internal selectable terminal block to connect 230V shutter output directly.

WARNING

Fire or Explosion Hazard.
Can cause severe injury, death, or property damage.

Close all manual fuel shutoff valves before starting this test to prevent an explosion.

WARNING

Electrical Shock Hazard.
Can cause severe injury, death, or property damage.

Use extreme care when testing the system. Line voltage is present on most terminal connections when power is on. Ensure proper selection of configuration jumpers before starting the burner operation.

CAUTION

Equipment Damage Hazard.
Improper testing can cause equipment damage.

Do not perform a dielectric test with the relay module installed. Internal surge protectors break down and conduct a current. This can cause the relay module to fail the dielectric test or destroy the internal lightning and high current protection.

1. Open the master switch before installing or removing a jumper on the subbase.
2. Before continuing to the next test, be sure to remove test jumper(s) used in the previous test.

3. Replace all limits and interlocks that are not operating properly. Do not bypass limits and interlocks.

Equipment Recommended

Voltmeter (1M ohm/volt minimum sensitivity) set on the 0 to 300 Vac scale and two jumper wires, No. 14 AWG (2.5 mm²) wire, insulated, 12 in. (304.8 mm) long with insulated alligator clips at both ends.

General Instructions

1. Perform all applicable tests listed in the Static Checkout, Table 4 or 5, in the order listed.
2. Make sure all manual fuel shutoff valves are closed.
3. For each test, open the master switch and install the jumper wire(s) between the subbase wiring terminals listed in the Test Jumpers column.
4. Close the master switch before observing operation.
5. Read the voltage between the subbase wiring terminals listed in the Voltmeter column.
6. If there is no voltage or the operation is abnormal, check the circuits and external devices as described in the last column.
7. Check all wiring for correct connections, tight terminal screws, correct wire, and proper wiring techniques.
8. Replace all damaged or incorrectly sized wires.
9. Replace faulty controllers, limits, interlocks, actuators, valves, transformers, motors and other devices, as required.
10. Make sure normal operation is obtained for each required test before continuing the checkout.
11. After completing each test, be sure to open the master switch and remove the test jumper(s).

Table 5. EC/RM7830A Static Checkout.

Test No.	Test Jumpers	Voltmeter	Normal Operation	If Operation is Abnormal, Check the Items Listed Below
1	None	5-L2	Line voltage at terminal 5.	<ol style="list-style-type: none"> 1. Master switch. 2. Power connected to the master switch. 3. Overload protection (fuse, circuit breaker, etc.) opened the power line.
2	None	17-L2	Line voltage at terminal 17.	Preignition interlocks.
3	5-16	—	Alarm (if used) turns on.	Alarm.
NOTE: Disconnect horn at this time (if used).				
4	5-16	2-20	Line voltage at terminal 20.	Limits in Lockout Circuit.
5	5-16	2-6	Line voltage at terminal 6.	<ol style="list-style-type: none"> 1. Recycle limits. 2. Burner control.
6	5-16 5-4	2-7	<ol style="list-style-type: none"> 1. Fan (Burner Motor or Blower) starts. 2. Line voltage at terminal 7. 	<ol style="list-style-type: none"> 1. Fan circuit. <ol style="list-style-type: none"> a. Manual Fan Switch. b. Fan power supply, overload protection and starter. c. Fan. 2. Running Limits or Airflow Switch (LD2 input).
NOTE: Remove jumpers and reconnect alarm (if used).				
7	5-10	—	Ignition spark (if ignition transformer is connected to terminal 10).	<ol style="list-style-type: none"> 1. Watch for spark or listen for buzz. <ol style="list-style-type: none"> a. Ignition electrodes are clean. b. Ignition transformer is okay.

Table 5. EC/RM7830A Static Checkout. (Continued)



Test No.	Test Jumpers	Voltmeter	Normal Operation	If Operation is Abnormal, Check the Items Listed Below
8	5-8	—	<ol style="list-style-type: none"> Ignition spark (if ignition transformer is connected to terminal 8). Automatic pilot valve opens (if connected to terminal 8). <p>NOTE: Refer to wiring diagram of system being tested.</p>	<ol style="list-style-type: none"> Watch for spark or listen for buzz. <ol style="list-style-type: none"> Ignition electrodes are clean. Ignition transformer is okay. Listen for click of fee head of valve for activation. <ol style="list-style-type: none"> Actuator, if used. Pilot valve.
9	5-21	—	Same as test no. 8 for connections to terminal 8. If using direct spark ignition, check the first stage fuel valve(s) instead of the pilot valve.	Same as test no. 8. If using direct spark ignition, check the first stage fuel valve(s) instead of the pilot valve.
10	5-9	—	Automatic fuel valve(s) open(s). If using direct spark ignition on a model with intermittent pilot on terminal 21, check the optional second stage fuel valve, if used.	<ol style="list-style-type: none"> Listen for and observe operation of the main fuel valve(s) and actuator(s). Valve(s) and actuator(s).
Final	 <p>CAUTION Equipment Damage Hazard. Failure to remove jumpers can damage equipment. After completing these tests, open the master switch and remove ALL test jumpers from the subbase terminals. Then remove bypass jumpers from the low fuel pressure limits (if used).</p>			

Table 6. EC/RM7850A Static Checkout.

Test No.	Test Jumpers	Voltmeter	Normal Operation	If Operation is Abnormal, Check These Items
1	None	4-2	Line voltage at terminal 4.	<ol style="list-style-type: none"> Master switch. Power connected to the master switch. Overload protection (fuse, circuit breaker, etc.) did not open the power line.
2	None	17-2	Line voltage at terminal 17.	Preignition interlocks.
3	4-16	—	Alarm (if used) turns on.	Alarm.
NOTE: Disconnect horn at this time (if used).				
4	4-16	2-20	Line voltage at terminal 20.	Limits in Lockout Circuit.
5	4-16	2-6	Line voltage at terminal 6.	<ol style="list-style-type: none"> Recycle limits. Burner control.
6	4-16 5-4	2-7	<ol style="list-style-type: none"> Fan (Burner Motor or Blower) starts. Line voltage at terminal 7. 	<ol style="list-style-type: none"> Fan circuit. <ol style="list-style-type: none"> Manual fan switch. Fan power supply, overload protection and starter. Fan. Running limits of Airflow Switch (LD2) input.
NOTE: Remove jumpers and re-connect alarm (if used).				
7	4-10	—	Ignition spark (if ignition transformer is connected to terminal 10).	<ol style="list-style-type: none"> Watch for spark or listen for buzz. <ol style="list-style-type: none"> Ignition electrodes are clean. Ignition transformer is okay.
8	4-8	—	Ignition spark (if ignition transformer is connected to terminal 8). Automatic pilot valve opens (if connected to terminal 8). Refer to wiring diagram of system being tested.	<ol style="list-style-type: none"> Watch for spark or listen for buzz. <ol style="list-style-type: none"> Ignition electrodes are clean. Ignition transformer is okay. Listen for click of fee head of valve for activation. <ol style="list-style-type: none"> Actuator, if used. Pilot valve.

Table 6. EC/RM7850A Static Checkout. (Continued)

Test No.	Test Jumpers	Voltmeter	Normal Operation	If Operation is Abnormal, Check These Items
9	4-21	—	Same test as no. 4 for connections to terminal 8. If using direct spark ignition, check the first stage fuel valve(s) instead of the pilot valve.	Same as test no. 4. If using direct spark ignition, check the first stage fuel valve(s) instead of the pilot valve.
10	4-9	—	Automatic main fuel valve(s) open(s). If using direct spark ignition on a model with intermittent pilot on terminal 21, check the optional second stage fuel valve, if used.	<ol style="list-style-type: none"> 1. Listen for and observe operation of the main fuel valve(s) and actuator(s). 2. Valve(s) and actuator(s).
11	12-13	18-L2	Voltmeter reads line voltage, then zero volts on terminal 18 after motor starts driving open.	<ol style="list-style-type: none"> 1. Low Fire Start Switch. 2. Firing rate motor and transformer.
12	12-13	19-L2	Firing rate motor drives open; line voltage at terminal 19 after motor is in High Fire position.	<ol style="list-style-type: none"> 1. High Fire Purge Switch. 2. Firing rate motor and transformer.
13	14-13	19-L2	Firing rate motor drives closed; zero volts at terminal 19 after motor starts driving closed.	<ol style="list-style-type: none"> 1. Low Fire Start Switch. 2. Firing rate motor and transformer.
14	15-13	—	<ol style="list-style-type: none"> 1. Raise setpoint of Series 90 controller—firing rate motor should drive toward open. 2. Lower setpoint of Series 90 controller—firing rate motor should drive toward closed. 	<ol style="list-style-type: none"> 1. Series 90 controller. 2. Firing rate motor and transformer.
Final	 <p>CAUTION Equipment Damage Hazard. Failure to remove jumpers can damage equipment. After completing these tests, open the master switch and remove all test jumpers from the subbase terminals. Also, remove bypass jumpers from the low fuel pressure limits (if used).</p>			

⚠ WARNING
Explosion hazard.
Can cause serious injury or death.
 Be sure all manual fuel shutoff valves are closed.

Mounting Other System Components (Fig. 6)

Refer to the applicable specifications for mounting other system components.

PRINCIPAL TECHNICAL FEATURES

The EC/RM7830A or EC/RM7850A Relay Module provide all customary flame safeguard functions as well as significant advancements in safety, annunciation, and system diagnostics.

Safety Shutdown (Lockout) Occurs If:

1. INITIATE Period
 - a. Purge card is not installed or removed.
 - b. Purge card is defective.
 - c. Configuration jumpers were changed (after 200 hours of operation).
 - d. AC line power errors, see Operation.
 - e. Four minute INITIATE period is exceeded.
2. STANDBY Period
 - a. Flame signal is present after 40 seconds.
 - b. Preignition Interlock is open an accumulative time of 30 seconds.
 - c. Airflow Switch feature is enabled and the Airflow Switch is closed for 120 seconds with Limits and Burner Control closed.
 - d. Ignition/pilot valve/intermittent pilot valve terminal is energized.
 - e. Main valve terminal is energized.
 - f. Internal system fault.
 - g. Purge card is not installed or removed.
 - h. Purge card is defective.
 - i. Lockout Input opens during STANDBY.
3. PURGE Period
 - a. Preignition Interlock opens anytime during purge.
 - b. Flame signal detected during purge.

- c. High Fire Switch fails to close within five minutes after the firing rate motor is commanded to drive to high fire position at start of purge (EC/RM7850A).
 - d. Low Fire Switch fails to close within five minutes, after firing rate motor is commanded to drive to low fire position at end of purge (EC/RM7850A).
 - e. Airflow Switch Input does not close within 10 seconds.
 - f. If Airflow Switch is disabled, there is no jumper between terminals 6 and 7.
 - g. Airflow Switch opens during PURGE.
 - h. Lockout Input opens during purge.
 - i. Ignition/pilot valve/intermittent pilot valve terminal is energized.
 - j. Main valve terminal is energized.
 - k. Internal system fault.
 - l. Purge card is removed.
 - m. Purge card is defective.
- 4. PREIGNITION**
- a. Lockout Input opens during PREIGNITION.
 - b. Airflow Switch opens during PREIGNITION.
 - c. Preignition Interlock opens during PREIGNITION.
 - d. Flame signal detected during PREIGNITION.
 - e. Ignition terminal is not energized.
 - f. Pilot valve/intermittent pilot valve terminal is energized.
 - g. Main valve terminal is energized.
 - h. Internal system fault.
 - i. Purge card is removed.
 - j. Purge card is defective.
- 5. SAFETY 1 PERIOD**
- a. Lockout Input opens during SAFETY 1.
 - b. Airflow Switch opens during SAFETY 1.
 - c. Low Fire Switch opens (EC/RM7850A).
 - d. No flame is present at the end of SAFETY 1.
 - e. Ignition terminal is not energized.
 - f. Pilot valve/intermittent pilot valve terminal is not energized.
 - g. Main valve terminal is energized.
 - h. Internal system fault.
 - i. Purge card is removed.
 - j. Purge card is defective.
- 6. PILOT STAB. PERIOD**
- a. Lockout Input opens during PILOT STAB.
 - b. Airflow Switch opens during PILOT STAB.
 - c. Low Fire Switch opens (EC/RM7850A).
 - d. No flame is present.
 - e. Ignition terminal is energized.
 - f. Pilot valve/intermittent pilot valve terminal is not energized.
 - g. Main valve terminal is energized.
 - h. Internal system fault.
 - i. Purge card is removed.
 - j. Purge card is defective.
- 7. MAIN TRIAL PERIOD**
- a. Lockout Input opens during MAIN TRIAL.
 - b. Airflow Switch opens during MAIN TRIAL.
 - c. Low Fire Switch opens (EC/RM7850A).
 - d. No flame is present.
 - e. Ignition terminal is energized.
 - f. Pilot valve/intermittent pilot valve terminal is not energized.
 - g. Pilot valve is energized during MAIN TRIAL stabilization.
 - h. Main valve terminal is not energized.
 - i. Internal system fault.
 - j. Purge card is removed.
 - k. Purge card is defective.
- 8. RUN Period.**
- a. No flame is present.
 - b. Lockout Input opens.
 - c. Ignition/interrupted pilot valve terminal is energized.
 - d. Main valve terminal is not energized.
 - e. Internal system fault.
 - f. Purge card is removed.
 - g. Purge card is defective.
 - h. Airflow Switch Input opens.
- 9. POSTPURGE Period.**
- a. Ignition/pilot valve/intermittent pilot valve terminal is energized.
 - b. Main valve terminal is energized.
 - c. Internal system fault.
 - d. Purge card is removed.
 - e. Purge card is defective.

OPERATION

Sequence of Operation

The relay modules have the operating sequences listed below; see Fig. 3 and 4. The relay module LED provide positive visual indication of the program sequence: POWER, PILOT, FLAME, MAIN and ALARM.

Initiate

The relay module enters the INITIATE sequence when the relay module is initially powered. The relay module can also enter the INITIATE sequence if the relay module verifies voltage fluctuations of +10/-15% or frequency fluctuations of $\pm 10\%$ during any part of the operating sequence. The INITIATE sequence lasts for two seconds unless the voltage or frequency tolerances are not met. When not met, a hold condition is initiated and displayed on the optional KDM for at least five seconds; when met, the INITIATE sequence restarts. If the condition is not corrected and the hold condition exists for four minutes, the relay module locks out. Causes for hold conditions in the INITIATE sequence:

- a. AC line dropout detection.
- b. AC line noise that can prevent a sufficient reading of the line voltage inputs.
- c. Low line voltage brownouts.

The INITIATE sequence also delays the burner motor starter from being energized and de-energized from an intermittent AC line input or control input.

Standby

The relay module is ready to start an operating sequence when the operating control input determines a call for heat is present. The burner switch, limits, operating limit control and all microcomputer-monitored circuits must be in the correct state for the relay module to continue into the PURGE sequence.

Normal Start-Up Purge

The relay module provides PURGE timing selectable from two seconds to thirty minutes with power applied and the operating control indicating a call for heat.

1. The Preignition Interlocks, Limits and Burner Control, Run/Test Switch, Airflow Switch Input, Lockout Input, and all microcomputer-monitored circuits must also be in the correct operating state.
2. The blower motor output, terminal 5, is powered to start the PURGE sequence. The firing rate motor is driven to the high fire position (EC/RM7850A). The PURGE timing does not begin until the Airflow Switch Input and High Fire Switch (EC/RM7850A) are both closed.
3. The Preignition Interlock Input must remain closed throughout PURGE or a safety shutdown occurs.
4. The Airflow Switch Input must close by ten seconds into PURGE or a safety shutdown occurs.
5. After the firing rate motor reaches the PURGE rate position and PURGE timing is completed, the motor drives to the low fire position (EC/RM7850A).

Ignition Trials

1. Preignition: With the firing rate motor at the low fire position (EC/RM7850A), the ignition transformer, terminal 10, is energized for three seconds.
2. First Safety Time (SAFETY1):
 - a. With the firing rate motor at the low fire position (EC/RM7850A):
 - (1) The pilot valves and ignition transformer, terminals 8, 10 and 21, are energized. Terminal 8 is an interrupted pilot valve and terminal 21 is an intermittent pilot valve.
 - (2) During SAFETY1, the Low Fire Switch Input must be closed. If it opens, a safety shutdown occurs (EC/RM7850A).
 - (3) The Preignition Interlock Input is ignored during SAFETY1, PILOT STAB., MAIN TRIAL, RUN and POSTPURGE.
 - b. Flame must be proven by the end of the First Safety Time to allow the sequence to continue. A safety shutdown occurs if there is no flame.
3. Pilot stabilization (PILOT STAB.): With flame proven, the ignition, terminal 10, is de-energized. The duration of this state is five seconds.
4. Main Trial (MAIN TRIAL):
 - a. The MAIN TRIAL time is selectable as three or five seconds. After PILOT STAB., and with the presence of a flame, the main fuel valve, terminal 9, is powered. If a flameout occurs, the relay module locks out within one or two seconds, depending on the amplifier Flame Failure Response Time (FFRT). Thus, the second safety time is defined as MAIN TRIAL time plus the amplifier FFRT.
 - b. During MAIN TRIAL, the Low Fire Switch Input must be closed (EC/RM7850A). If it opens, a safety shutdown occurs.
 - c. After three or five seconds of MAIN TRIAL, terminal 8 is de-energized for main stabilization. Flame must remain proven during this five-second period.

Run

1. The firing rate motor releases to modulation.
2. The relay module is now in RUN and remains in RUN until the controller input, terminal 6, opens, indicating that the demand is satisfied or a limit has opened.

Postpurge

The relay module (model specific) provides a two-, 15- or 30-second POSTPURGE following the completion of the RUN period. The blower motor output is powered to drive all combustion products and any unburned fuel from the combustion chamber. It also supplies combustion air to burn fuel being purged from the fuel line downstream from the fuel shutoff valve.

1. The main fuel valve and the intermittent pilot valve, terminals 9 and 21, are de-energized and the firing rate motor is commanded to the low fire position (EC/RM7850A) to begin the POSTPURGE period.
2. The Preignition Interlock Input is ignored during POSTPURGE.
3. After the POSTPURGE period is completed, the relay module re-enters STANDBY.

Run/Test Switch

The Run/Test Switch is located on the top side of the relay module, see Fig. 5. The Run/Test Switch allows the burner sequence to be altered as follows:

1. In Purge Drive to High Fire position, the Run/Test Switch, when placed in the TEST position, holds in PURGE with the firing rate motor in the High Fire position (EC/RM7850A).
2. In the measured PURGE sequence, the Run/Test Switch, placed in the TEST position, causes the PURGE timing to stop. The firing rate motor is in the High Fire position.
3. In Purge Drive to Low Fire position, the Run/Test Switch, when placed in the TEST position, holds the burner in PURGE with the firing rate motor in the Low Fire position (EC/RM7850A).
4. During the PILOT STAB. period, the Run/Test Switch, when placed in the TEST position, stops the timer, allowing for pilot turn-down test and other burner adjustments. This activates a 15-second flameout timer that permits pilot flame adjustment without nuisance safety shutdowns.
5. During Run, the Run/Test Switch, when placed in the TEST position, drives the firing rate motor to the Low Fire position.

IMPORTANT

When the relay module is switched to the TEST mode, it stops and holds at the next Run/Test Switch point in the operating sequence. Make sure that the Run/Test Switch is in the RUN position before leaving the installation.

SETTINGS AND ADJUSTMENTS

Selectable Site-Configurable Jumpers

The relay module has three site-configurable jumper options, see Fig. 6 or 7 and Table 7. If necessary, clip the site-configurable jumpers with side cutters and remove the resistors from the relay module. The relay module

reads the settings of these configuration jumpers at startup. After 200 hours of main valve operation, the relay module locks the jumper settings into internal memory. If these jumpers are changed after the 200 hours occur, the relay module locks out. This safety function assures that the relay module cannot be modified after it is installed in a particular location.

If JR3 (Airflow Switch) is intact (no Airflow Switch), then a jumper must be installed between terminals 6 and 7. If JR3 is clipped (Airflow Switch is present), the relay module locks out if it detects a jumper between terminals 6 and 7.

SERVICE NOTE: Clipping and removing a site-configurable jumper enhances the level of safety.

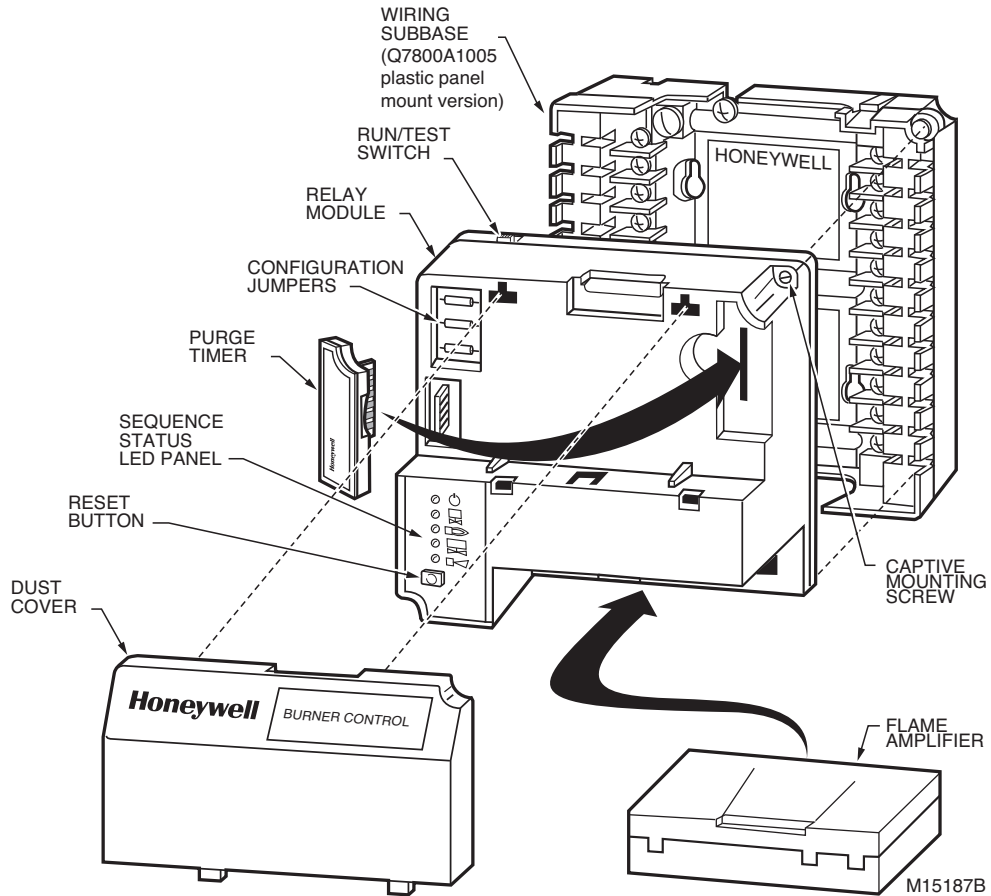

Fig. 6. EC/RM7830A and EC/RM7850A Relay Modules exploded view.

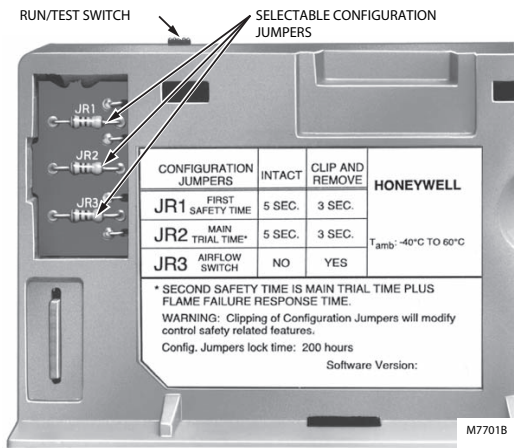

Fig. 7. Selectable site-configurable jumpers.

Table 7. Site-configurable jumper options.

Jumper Number	Description	Intact	Clipped
JR1	First Safety Time	5 seconds ^a	3 seconds ^a
JR2	Main Trial Time	5 seconds	3 seconds
JR3	Airflow Switch	No	Yes

^a EC7850A1148 or RM7850A1035
Intact—3 seconds Clipped—2 seconds

IMPORTANT

Clipping site-configurable jumpers after 200 hours of operation results in a nonresettable Code 110, LOCKOUT. The relay module must be replaced.

Flame Signal Measurement

Measure the flame signal at the appropriate times as defined in the applicable flame amplifier specifications.

SAFETY AND SECURITY

Physical device protection

Device shall be accessible to authorized personnel only – Installation on publicly accessible places is not recommended as this could lead to unwanted and potentially unsafe changes to device (wiring, configuration, etc).

It is recommended to lock the device in an enclosed cabinet with access allowed only to approved and trained personnel. Also, it is strongly advised to keep all the wiring of device physically secure.

Physical protection of the device is applied via Run/Test switch label/seal. It is intended to prevent and detect unauthorized access.

Modbus & DDL Interface security

Any conducts critical to device functionality (DDL, Modbus lines etc.) shall be physically protected (installed outside public access) since they could be damaged or tampered-with by unauthorized people, either accidentally or for purpose.

Modbus RS-485 & DDL protocols do not support security features. For DDL interface - only DDL devices shall be connected to the Burner Controller DDL line.

License agreement

Copying and reverse engineering is prohibited by the law.

For More Information

The Honeywell Thermal Solutions family of products includes Honeywell Combustion Safety, Eclipse, Exothermics, Hauck, Kromschröder and Maxon. To learn more about our products, visit ThermalSolutions.honeywell.com or contact your Honeywell Sales Engineer.

Honeywell Process Solutions

Honeywell Thermal Solutions (HTS)
1250 West Sam Houston Parkway
South Houston, TX 77042
ThermalSolutions.honeywell.com

® U.S. Registered Trademark
© 2019 Honeywell International Inc.
32-00198-01 M.S. 04-19
Printed in United States

Honeywell