

Burner control unit BCU 370

Technical Information · GB
6 Edition 01.19

- For modulating, forced draught burners for gas of unlimited capacity in intermittent or continuous operation
- Control of fan and butterfly valve
- Simple system set-up thanks to optional tightness control and integrated ignition unit
- Easy start-up and maintenance thanks to Manual operating mode
- Optionally available with integrated fieldbus interface for simple wiring



Contents

Burner control unit BCU 370	1
Contents	2
1 Application	4
1.1 Applications example	6
1.1.1 Modulating-controlled forced draught burner	6
1.1.2 Modulating-controlled forced draught burner with tightness control	6
1.1.3 Modulating-controlled forced draught burner with pilot burner and tightness control	7
1.1.4 Controlling the BCU via PROFIBUS DP	8
1.1.5 Controlling the BCU and the butterfly valve via PROFIBUS DP	8
2 Certification	9
3 Function	10
3.1 Connection diagrams	10
3.1.1 BCU 370	10
3.1.2 BCU 370 with actuator IC 20	14
3.1.3 Capacity control by adjusting the valve between the Open position and a separate Min position	15
3.1.4 BCU 370..B1 with PROFIBUS DP	16
3.1.5 Assignment of connection terminals	17
3.2 BCU 370 program sequence	19
3.2.1 Normal start-up	19
3.2.2 Quick start, butterfly valve waits in the Ignition position	21
3.2.3 Quick start, butterfly valve waits in the Closed position	23
3.2.4 Start-up without pre-purge, butterfly valve waits in the Closed position	25
3.2.5 Controlled air flow	27
3.3 Tightness control	28
3.3.1 Program sequence	30
3.4 PROFIBUS DP	32
3.4.1 Safety-related control signals	32
3.4.2 BCSOft	33

3.4.3 Configuration, master-slave procedure	33
3.4.4 Addressing	33
3.4.5 Network technology	34
3.4.6 Configuration	34
3.4.7 Bus communication	34
3.5 Program status	36
3.6 Fault message (blinking)	37
3.6.1 Reaction to process faults	38
4 Parameters	40
4.1 Scanning the parameters	42
4.2 Flame control	42
4.2.1 Burner flame signal	42
4.2.2 Burner switch-off threshold	42
4.2.3 UVS check (1× in 24 hours)	43
4.3 Behaviour during start-up	44
4.3.1 Minimum burner pause time t_{BP}	44
4.3.2 Burner start-up attempts	44
4.3.3 Switch-on delay time t_E	45
4.3.4 Pre-ignition time t_{VZ}	45
4.3.5 1 st safety time on start-up, burner/pilot burner t_{SA1}	46
4.3.6 1 st flame proving period, burner/pilot burner t_{FS1}	46
4.3.7 2 nd safety time on start-up, main burner t_{SA2}	47
4.3.8 2 nd flame proving period, main burner t_{FS2}	47
4.4 Behaviour during operation	48
4.4.1 Minimum operating time t_B	48
4.4.2 Controller enable signal delay time t_{RF}	48
4.4.3 Safety time during operation t_{SB}	48
4.4.4 Restart after flame failure during operation	49
4.4.5 Last fault signal	49
4.4.6 V2 during burner operation	50
4.5 Monitoring/tightness control	51
4.5.1 Min. gas pressure monitoring	51
4.5.2 Digital input function	51
4.5.3 Air monitoring during pre-purge	52
4.5.4 Air monitoring during operation	53
4.5.5 Tightness control, test period t_p	54

4.6 Air control	56	6.12 Protective circuits	69
4.6.1 Valve control	56	6.13 BCSoft	69
4.6.2 Pre-purge	56	7 Flame control	70
4.6.3 Quick start starts in	57	7.1 ...with flame rod	70
4.6.4 Pre-purge time t_{PV}	58	7.2 ...with UV sensor	70
4.6.5 Post-purge time t_{PN}	59	8 Accessories	71
4.6.6 Fan run-up time t_{GV}	60	8.1 High-voltage cable	71
4.7 Control using PROFIBUS DP	61	8.2 BCSoft	71
4.7.1 Bus control activation	61	8.2.1 Opto-adapter PCO 200	71
4.7.2 Bus control limitation	61	8.3 Radio interference suppressed terminal boots	71
4.8 Manual mode	63	8.4 Connection kit BCU 370	71
4.8.1 Operating time in Manual mode	63	8.5 Set of stickers BCU 370	71
4.9 Fault messages	64	8.6 GSD master data file for BCU 370..B1	72
4.9.1 The last 10 fault messages	64	9 Technical data	73
4.10 Password	64	9.1 PROFIBUS DP	74
4.10.1 User-defined password	64	9.2 Operating controls and dimensions	75
5 Selection	65	9.3 Converting units	76
5.1 Type code	65	10 Legend	77
6 Project planning information	66	11 Glossary	78
6.1 Cable selection	66	11.1 Safety shut-down	78
6.1.1 Ionization cable	66	11.2 Fault lock-out	78
6.1.2 UV cable	66	11.3 Warning signal	78
6.1.3 Ignition cable	66	11.4 Timeout 25 s/250 s	78
6.2 Fan control	67	12 Annex	79
6.3 Controlling the butterfly valve	67	12.1 Status and fault messages for PROFIBUS DP	79
6.4 Safety interlock (limits)	67	Feedback	82
6.5 Too many remote resets	67	Contact	82
6.6 Protecting the ignition unit from overload	68		
6.7 Wiring	68		
6.7.1 Single-electrode operation with external ignition unit	68		
6.8 BCU switched off	68		
6.9 Note on EC type-examination or CSA and FM approval	69		
6.10 Contact fuses	69		
6.11 Installation	69		



BCU 370

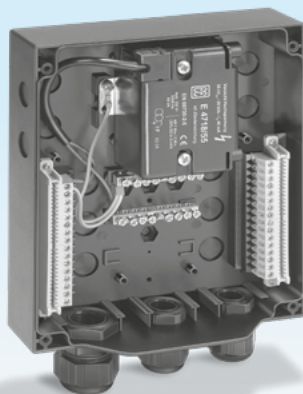

Lower section

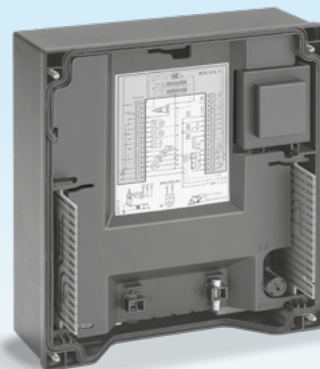

Upper section

1 Application

The BCU 370 burner control unit controls, ignites and monitors industrial forced draught burners of unlimited capacity in intermittent or continuous operation.

It can be used for directly ignited forced draught burners or forced draught burners ignited with pilot burner. The BCU 370 activates the fan and sets the connected butterfly valve to Pre-purge and Ignition position. After pre-purge and burner start, the enable signal is issued to an external controller which positions the butterfly valve in accordance with the capacity demand. Post-purge occurs after the end of burner operation. The burner control unit BCU 370 monitors the gas and air pressure. An optionally integrated tightness control

function checks the valves with an external gas pressure switch.

Programmability by means of the optical interface and BCSOFT PC software guarantees optimum adaptation to the relevant application. Adjustable start-up attempts and automatic restart which can be activated ensure the high flexibility of the burner equipment.

The quick-start option allows standard-compliant start-up of the forced draught burner without pre-purge after controlled shut-down. This avoids unnecessary admission of air into the combustion chamber. The heat output is available as quickly as possible after a temperature demand.



Application

The program status, the unit parameters and the level of the flame signal can be read directly from the BCU. An integrated Manual mode allows manual start of the burner and setting of the butterfly valve position independently of the central control system. The BCSoft operator-control and setting software provides a powerful tool for commissioning and servicing.

To reduce the installation and wiring costs, Honeywell Kromschröder offers an optional Profibus DP interface to transfer the activation signals and feedbacks.

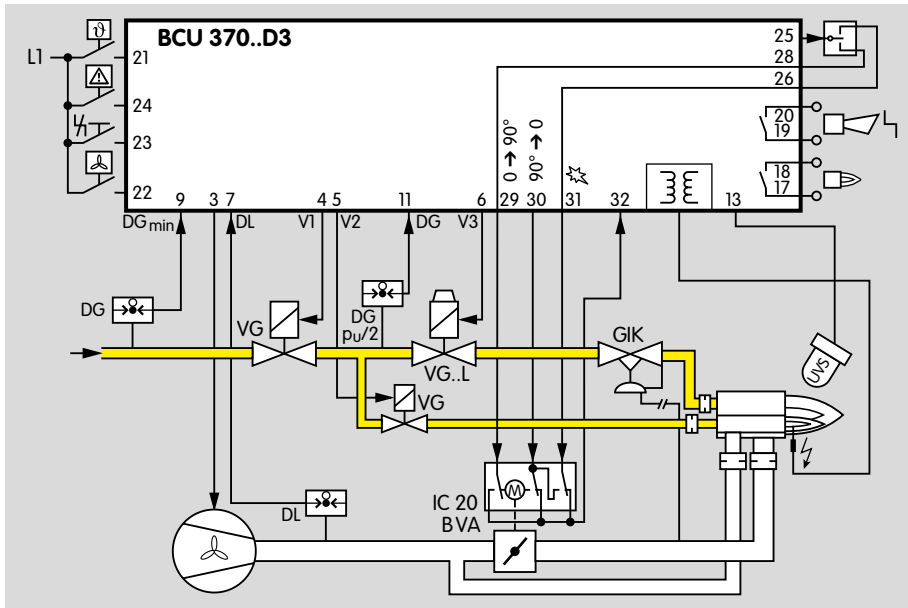

1.1.3 Modulating-controlled forced draught burner with pilot burner and tightness control

A pilot burner ignites the main burner and is switched off during the main burner's safety time.

Parameter 27 = 0: V2 is "OFF", i.e. interrupted pilot burner, during burner operation.

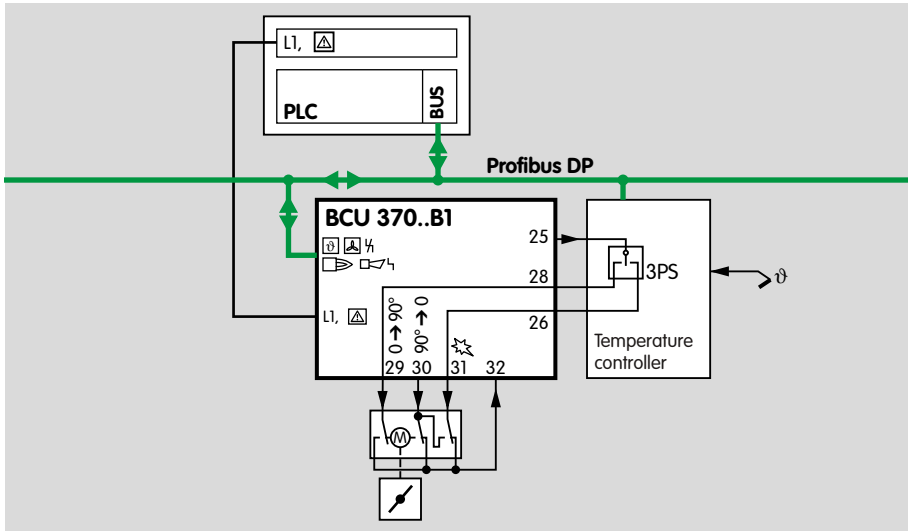

1.1.4 Controlling the BCU via PROFIBUS DP

The BCU 370..B1 issues the enable signal to the temperature controller for capacity control. The temperature controller then controls the butterfly valve directly.

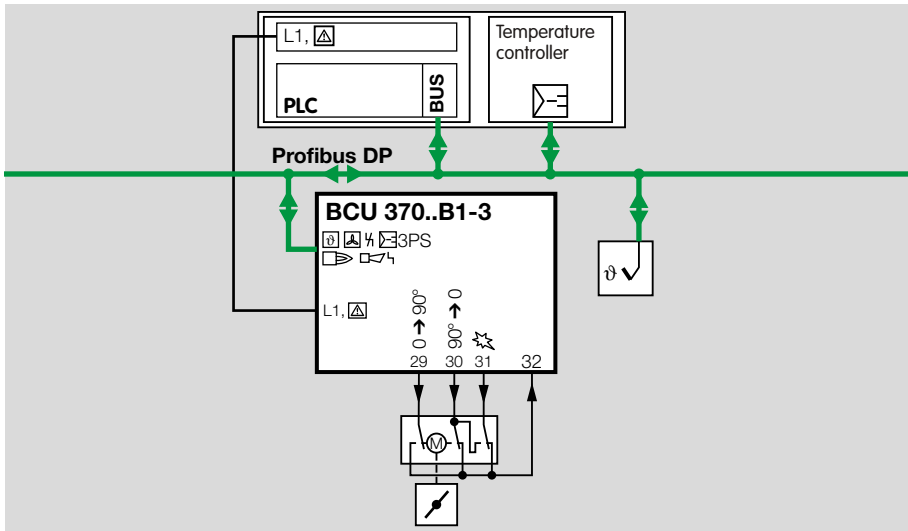

1.1.5 Controlling the BCU and the butterfly valve via PROFIBUS DP

The BCU 370..B1-3 receives positioning information for the butterfly valve from the temperature controller via the PROFIBUS DP and activates the butterfly valve following controller enable.

2 Certification

Certificates – see www.docuthek.com

EU certified pursuant to



Directive:

- Low Voltage Directive (2014/35/EU),
- EMC Directive (2014/30/EU).

Regulation:

- Gas Appliances Regulation (EU) 2016/426

FM approved



Factory Mutual Research Class: 7611 “Combustion Safeguards and Flame Sensing Systems”. Suitable for applications pursuant to NFPA 86.

www.approvalguide.com

ANSI/CSA approved



American National Standards Institute/Canadian Standards Association – Class number: 3335-01 and 3335-81.

UL listed

USA and Canada



Underwriters Laboratories – UL 372 “Primary Safety Controls for Gas and Oil-fired Appliances”.

www.ul.com → Tools (at the bottom of the page) → On-line Certifications Directory

AGA approved



Australian Gas Association, Approval No.: 6880

http://www.aga.asn.au/product_directory

Eurasian Customs Union



The product BCU 370 meets the technical specifications of the Eurasian Customs Union.

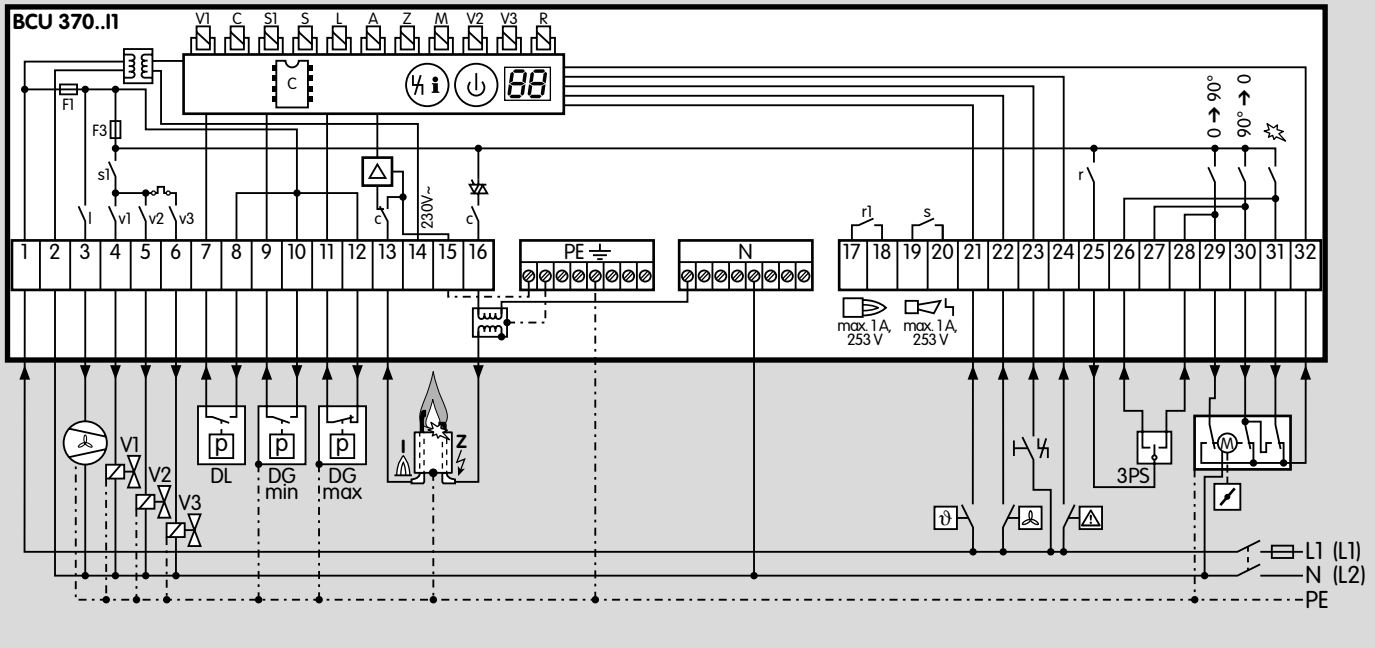

3 Function

3.1 Connection diagrams

3.1.1 BCU 370

The drawing shows the BCU 370..I1 with integrated ignition unit, ionization control and double-electrode operation.

For cable selection and wiring, see page 66 (Project planning information).

For the explanation of symbols, see page 77 (Legend).



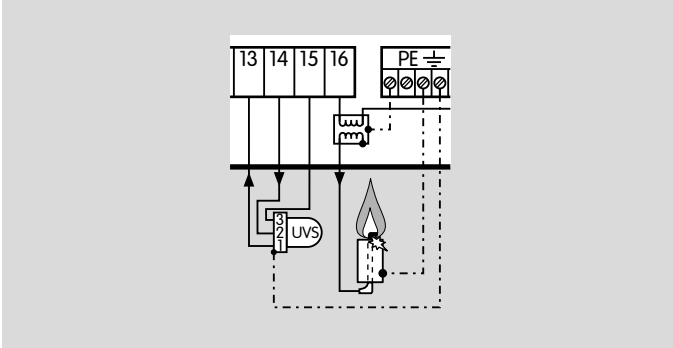

BCU 370..I1 for 120 V and 230 V, UV control

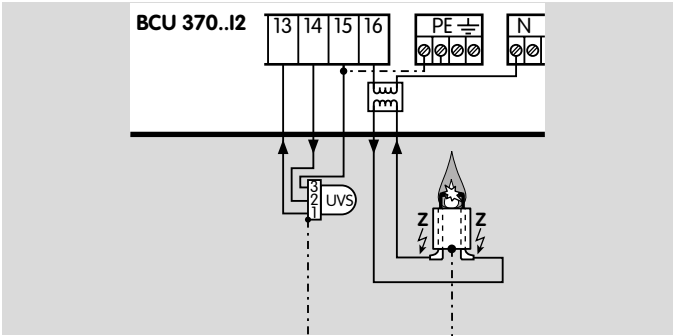

BCU 370..I2 for 230 V, ignition by electrode to electrode

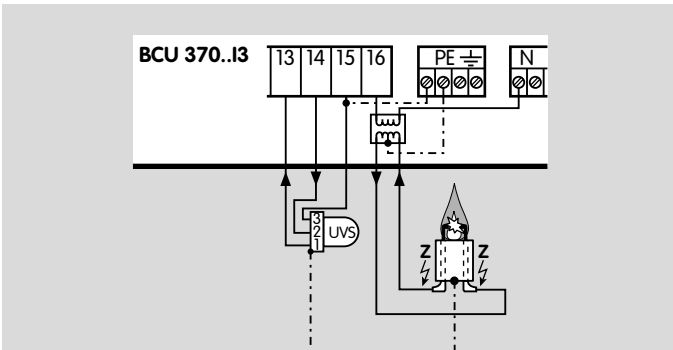

BCU 370..I3 for 120 V, ignition by electrode to electrode with centre tap for secondary grounding



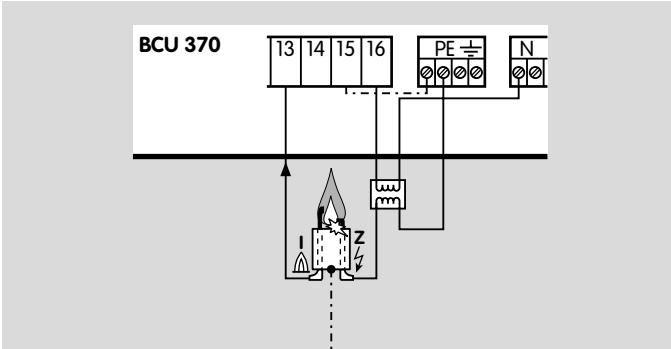

BCU 370 with external ignition transformer, e.g. TZI or TGI

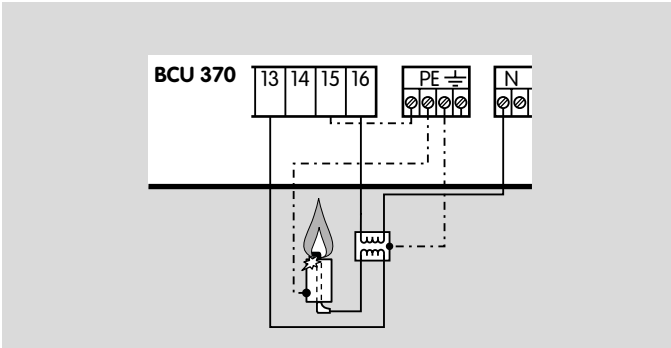

BCU 370 with single-electrode operation, which requires an external ignition transformer TZI or TGI

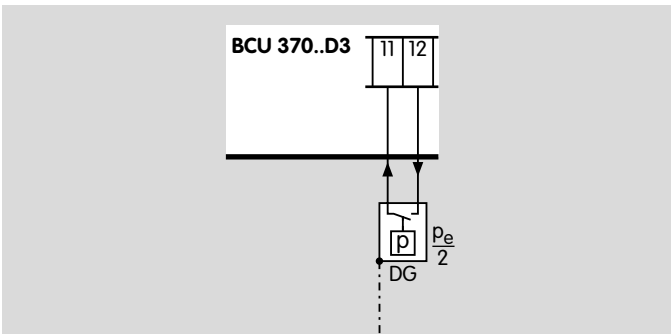

BCU 370..D3, gas pressure switch DG for tightness control



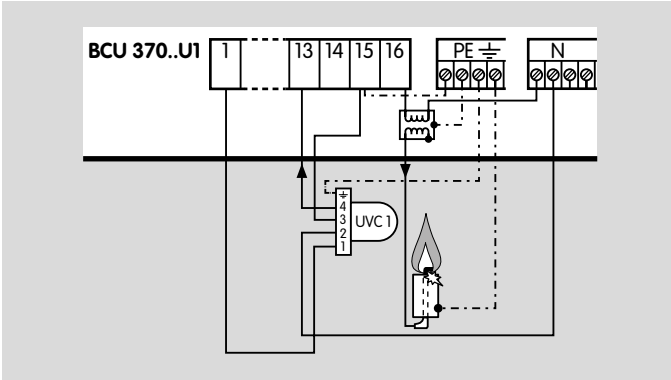

BCU 370..U1 with UV flame detector UVC 1 for continuous operation

Use 5-core connection cable including a PE wire and complying with local regulations.

The UVC 1 is grounded using a PE wire connection which is galvanically connected to the housing.

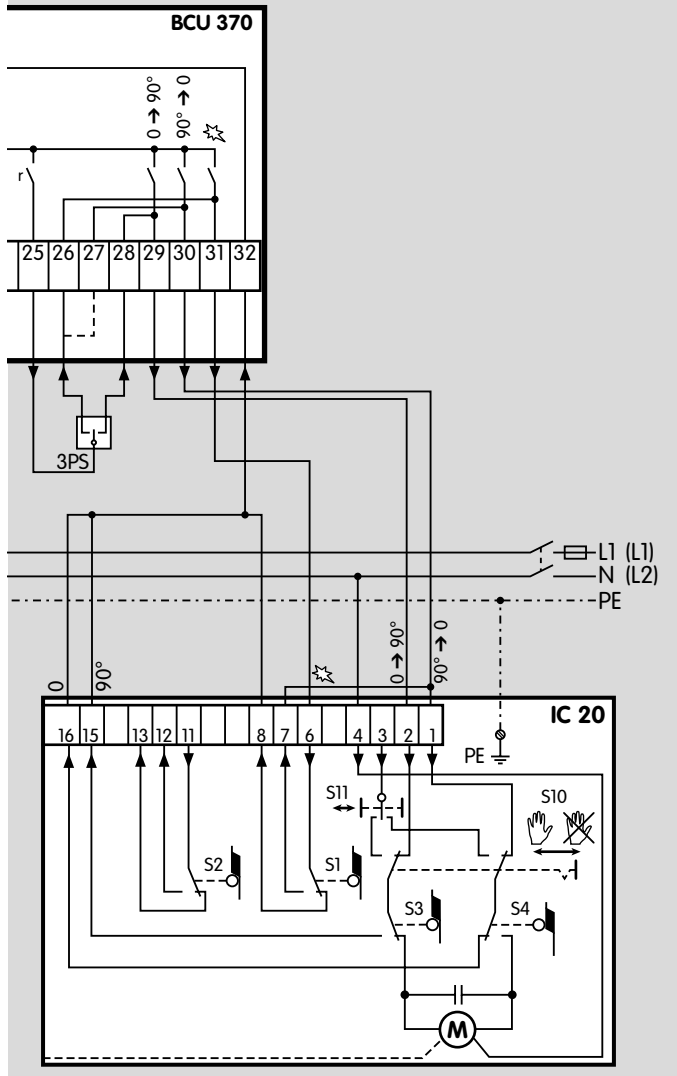

3.1.2 BCU 370 with actuator IC 20

The “closed contact” (90° → 0) of the external three-point step controller (3PS) can be connected to terminal 26 or 27.

Terminal 26: the controller operates between the open and ignition positions.

Terminal 27: the controller operates between the open and closed positions.

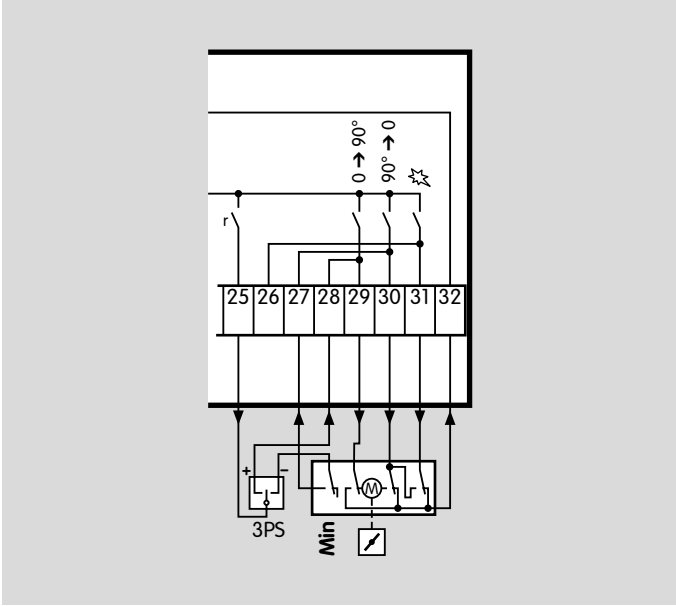

3.1.3 Capacity control by adjusting the valve between the Open position and a separate Min position

This connection is used if the valve position to be approached is below the Ignition position.

Standard wiring of BCU 370 and BCU 370..B1 without three-point step control function

Valve position	Activation of terminal
Upper end position Open	28
Lower end position Closed	27
Lower end position Min	Via separate limit switch
Lower end position Ignition	26

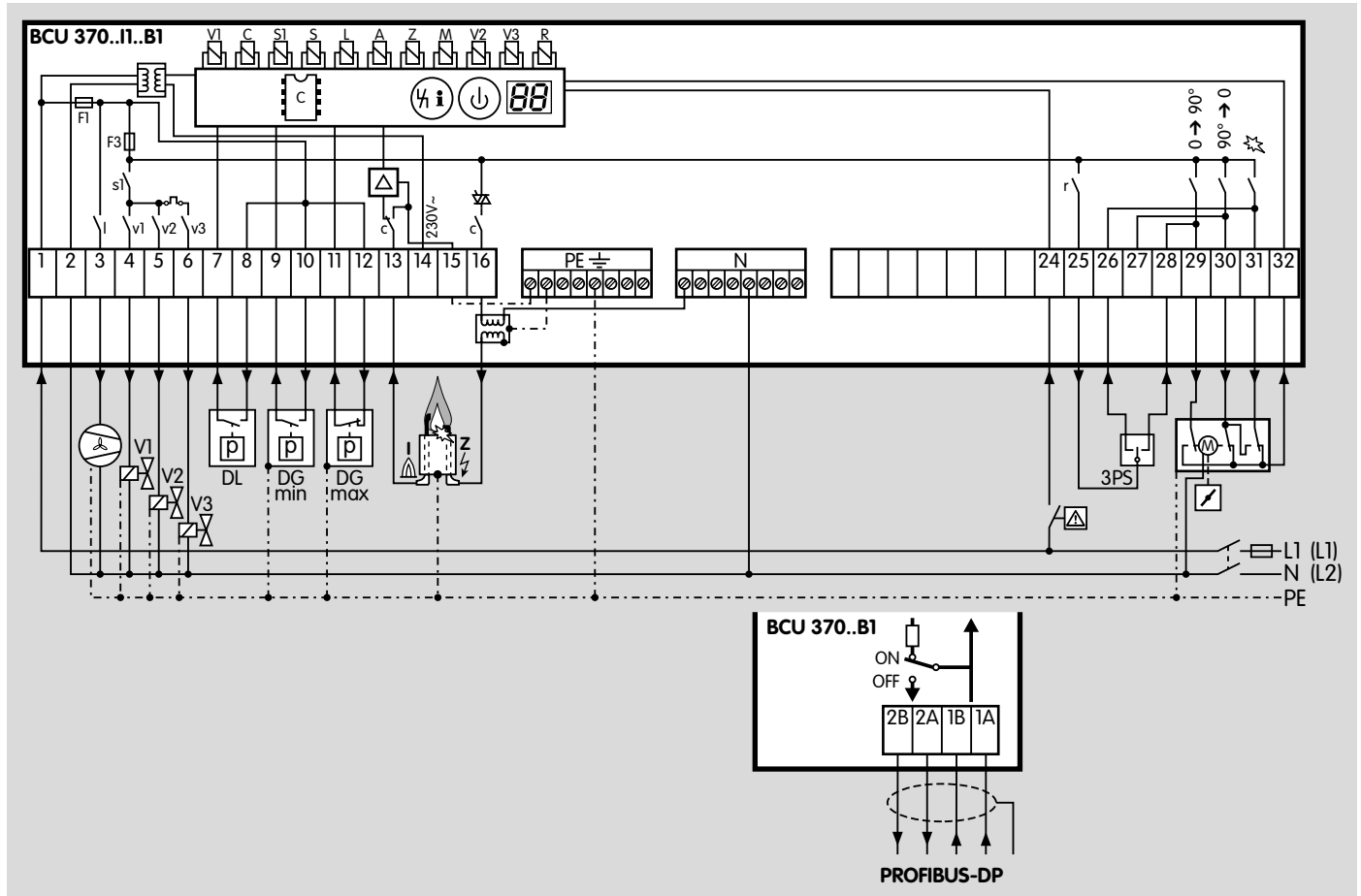

3.1.4 BCU 370..B1 with PROFIBUS DP

Function, see page 32 (PROFIBUS DP)

For cable selection and wiring, see page 66 (Project planning information).

For the explanation of symbols, see page 77 (Legend).

3.1.5 Assignment of connection terminals

Terminal	Type	Designation	Function
1, 2	V AC input	Supply voltage	Voltage to operate the BCU, 1 = phase (L1), 2 = neutral conductor (N)
3	V AC output	Fan	Connection for fan control
4	Safety circuit output	Gas valve V1	Connection of phase for gas valve V1
5		Gas valve V2	Connection of phase for gas valve V2
6		Gas valve V3	Connection of phase for gas valve V3
7	Inputs for pressure switches	Minimum air pressure	Connection for pressure switch to monitor the minimum air pressure
9		Minimum gas pressure	Connection for pressure switch to monitor the minimum gas pressure
11		Maximum gas pressure	Connection for pressure switch to monitor the maximum gas pressure
8, 10 and 12	V AC outputs	Mains supply	Phase for pressure switch mains supply
13	Flame control	Flame amplifier input	Input for flame amplifier
14		Supply voltage to UV sensor	Output for supply voltage to UV sensor
15		Burner ground	Burner ground input for UV sensor
16		Ignition transformer output	Output for (external) ignition transformer
17, 18 ^{1) 2)}	Floating contact	Signalling contact for operating signals	Contact between terminals 17 and 18 closes once the operating signal has been received from the burner
19, 20 ^{1) 2)}		Signalling contact for faults	Contact between terminals 19 and 20 closes in the event of a BCU fault signal
21 ^{1) 2)}	V AC input	Start-up signal	Signal applied: BCU start; no signal: BCU stop
22 ^{1) 2)}		Controlled air flow	Signal applied: fan is started to supply air to the combustion chamber for cooling, for example. Only functional in standby. The function is deactivated as soon as a signal is received at terminal 1 (BCU start).
23 ^{1) 2)}		Remote reset	Input for external signal (button) to reset the unit after a fault lock-out
24		Controller enable/emergency stop	Connection for higher-level safety devices and interlocks (e.g. emergency stop)
25 ²⁾	Connection for external three-point step controller	Controller enable	Output signal for controller enable for the three-point step controller. The actuator can be set to various positions.
26 ²⁾		Y- (to ignition position)	Connection for the signal to activate the ignition position
27 ²⁾		Y- (to min. position)	Connection for the signal to activate the position for minimum capacity
28 ²⁾		Y+ (to max. position)	Connection for the signal to activate the position for maximum capacity



Function

Terminal	Type	Designation	Function
29, 30 and 31	VAC output	Capacity control	Connection for capacity control using an actuator
32	Safety circuit input	Feedback from actuator/ frequency converter	Connection for the position feedback signal from the actuator

¹⁾ BCU..B1: not fitted/non-functional

²⁾ BCU..B1-3: not fitted/non-functional

3.2 BCU 370 program sequence

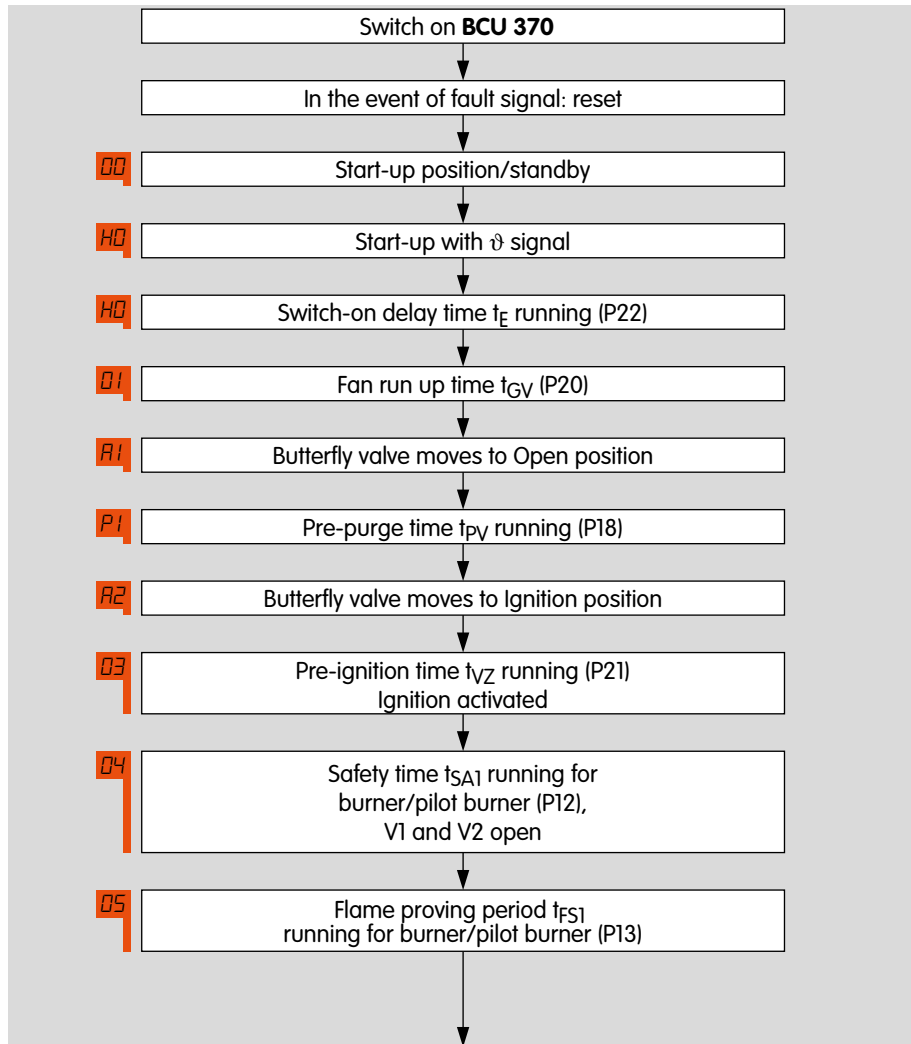

3.2.1 Normal start-up

If a fault from the preceding operating cycle is still being signalled after switching on, it will be necessary to reset this first. Once the start-up signal (ϑ) has been applied, the switch-on delay t_E starts to elapse.

During the fan run-up time t_{GV} which follows, the fan starts with the butterfly valve being closed. The butterfly valve then moves from the Closed to the Open position. After pre-purge, it moves back to the Ignition position.

The running times depend on the respective actuator. The BCU waits for actuator feedback before continuing the program sequence.

Now the BCU activates pre-ignition t_{VZ} and then opens valves V1 and V2 for the pilot burner. The ignition time t_Z is constant.

After the flame proving period for the pilot burner t_{FS1} , valve V3 opens to ignite the main burner.



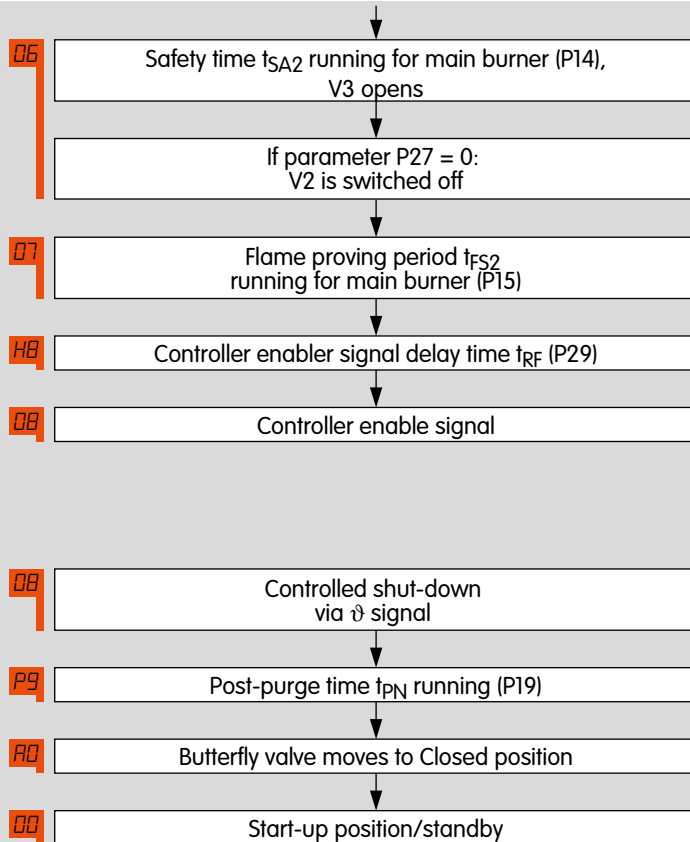

If parameter 27 = 0, V2 closes at the end of the main burner safety time t_{SA2} . The pilot burner is switched off.

Then the flame proving period for the main burner t_{FS2} and the controller enable signal delay time t_{RF} start to elapse. Afterwards, the BCU issues the enable signal to the controller.

If there is no pilot burner, program steps [06](#) and [07](#) will be omitted.

As soon as the start-up signal (ϑ) is switched off, post-purge starts. The butterfly valve moves to the Ignition position during this time, then to the Closed position. Next, the BCU rests in the start-up position/standby.

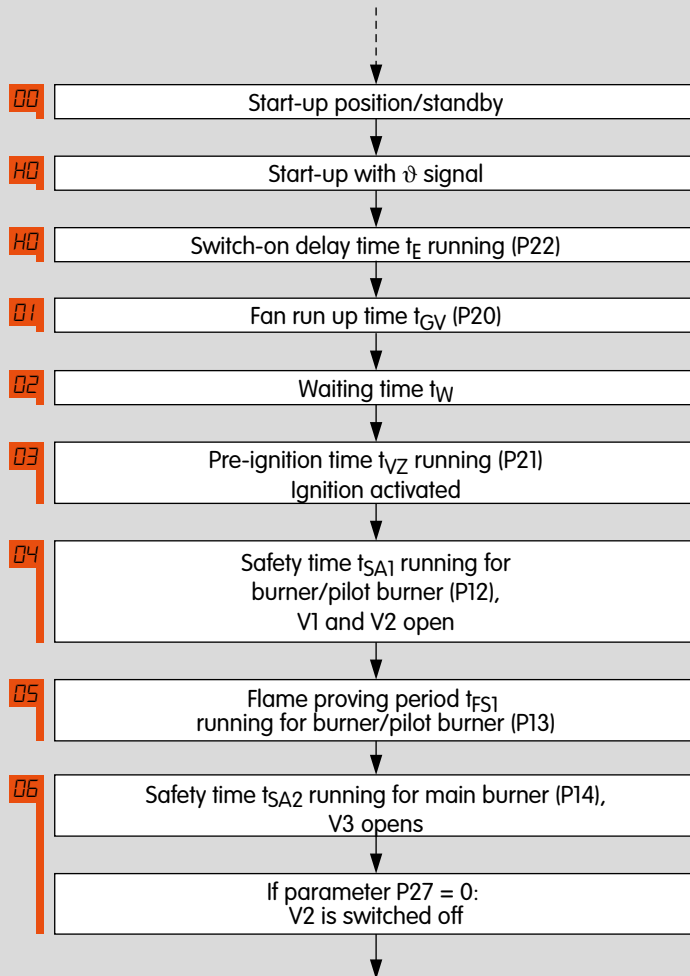

3.2.2 Quick start, butterfly valve waits in the Ignition position

Parameter 06 = 0, parameter 28 = 0

Quick start is the same as normal start, except that pre-purge is dispensed with. The burner starts quicker. This results in improved control quality, since there is no dead time, the energy is used better and no cold air is fed to the combustion chamber.

The BCU 370 only carries out a quick start if the last shut-down was a controlled shut-down. No more than 24 hours may have elapsed and the BCU must have been switched on.

In contrast to the “normal start-up”, in the case of a quick start, program steps [R1](#), [P1](#) and [R2](#) will be omitted.

If there is no pilot burner, program steps [06](#) und [07](#) will also be omitted.



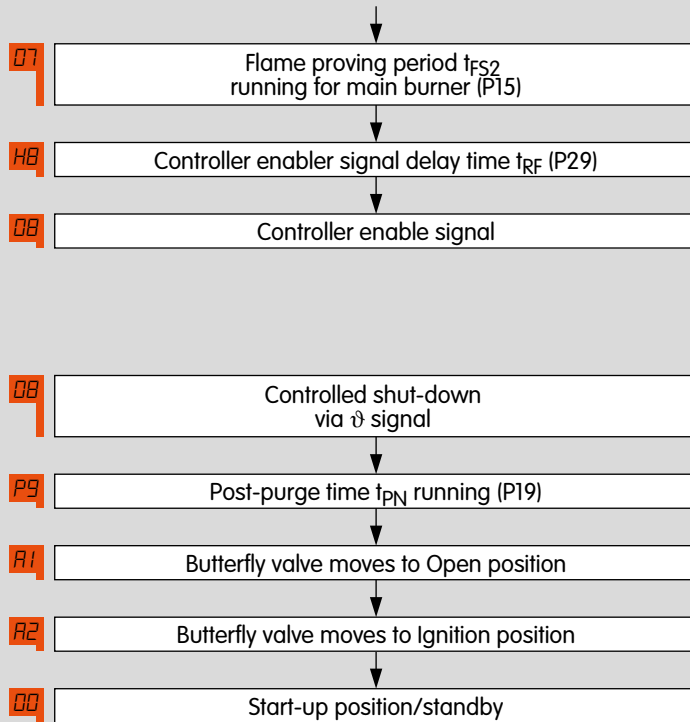

After controlled shut-down, the post-purge time t_{PN} starts to elapse and then the butterfly valve moves to the Ignition position in preparation for the next start.

NOTE: Quick start is not allowed for units with FM or CSA approval.

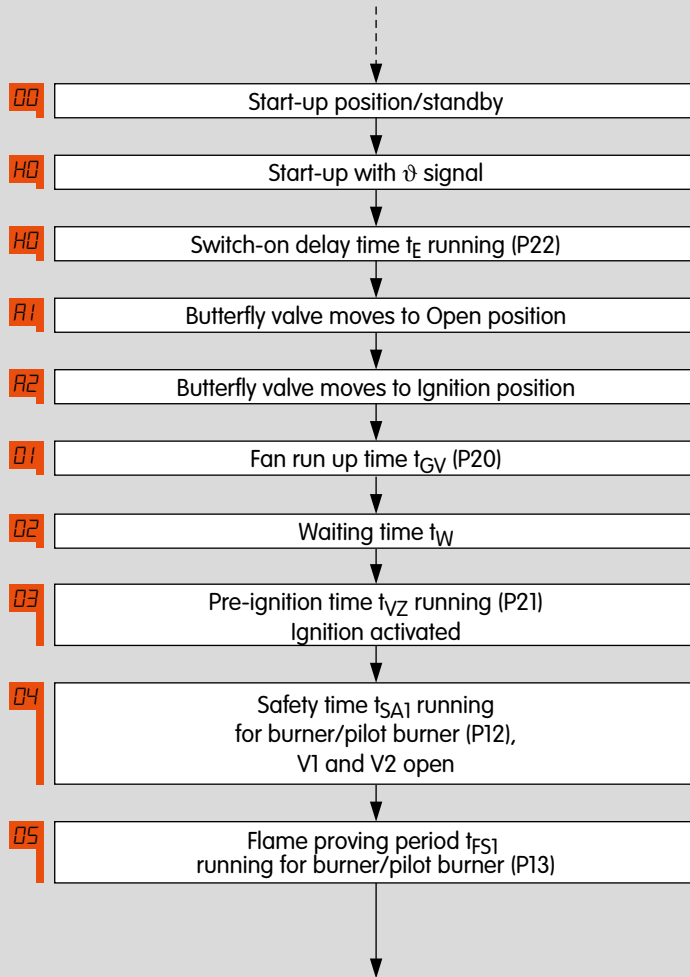

3.2.3 Quick start, butterfly valve waits in the Closed position

Parameter 06 = 0, parameter 28 = 1

Pre-purge will also be omitted for this type of quick start. To prevent cold air from entering the combustion chamber while the BCU is in start-up position/standby, the butterfly valve waits in the Closed position.

The BCU 370 only carries out a quick start if the last shut-down was a controlled shut-down. No more than 24 hours may have elapsed and the BCU must have been switched on.

After the switch-on delay time t_E , the butterfly valve moves to the Ignition position. The Ignition position is always approached from the top. Therefore, the butterfly valve moves to the Open position first.



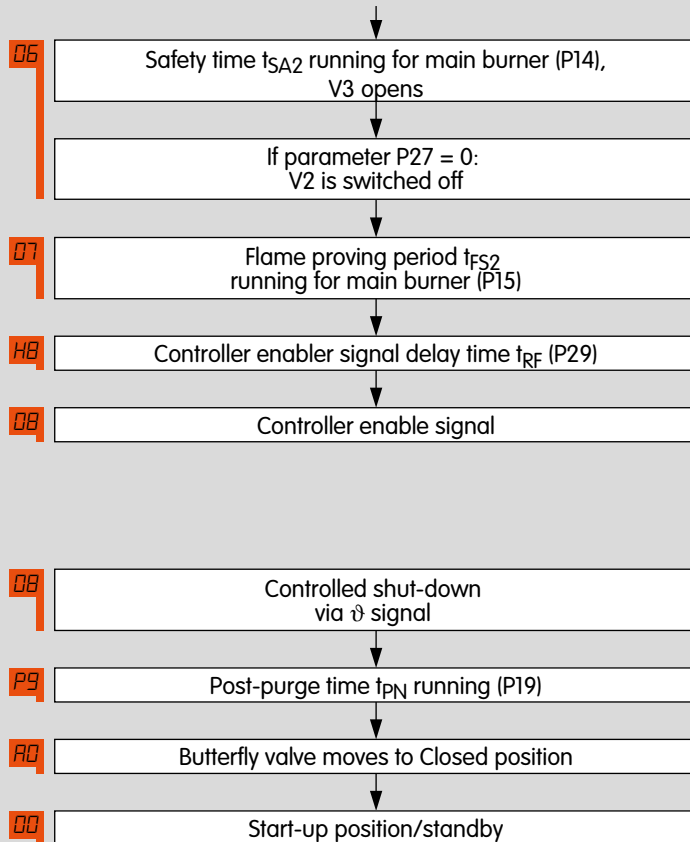

If there is no pilot burner, program steps 06 and 07 will be omitted.

As soon as the start-up signal (ϑ) is switched off, post-purge starts. The butterfly valve moves to the Ignition position during this time, then to the Closed position. Next, the BCU rests in the start-up position/standby.

NOTE: Quick start is not allowed for units with FM or CSA approval.

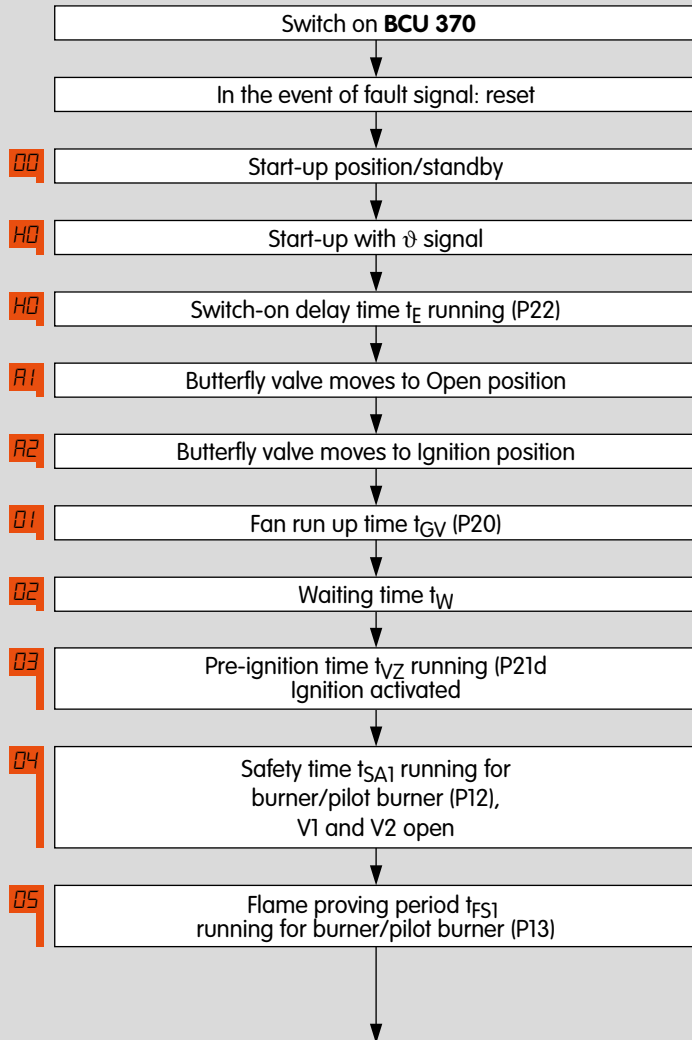

3.2.4 Start-up without pre-purge, butterfly valve waits in the Closed position

Parameter 18 = 0, parameter 28 = 1

If a fault from the preceding operating cycle is still being signalled after switching on, it will be necessary to reset this first. Once the start-up signal (ϑ) has been applied, the switch-on delay t_E starts to elapse.

Afterwards, the butterfly valve moves from the Closed to the Open position and then to the Ignition position. During the fan run-up time t_{GV} which follows, the fan starts with the butterfly valve being set to Ignition position.

After the waiting time t_W , the BCU activates pre-ignition t_{VZ} and then opens valves V1 and V2 for the pilot burner. The ignition time t_Z is constant. After the flame proving period for the pilot burner t_{FS1} , valve V3 opens to ignite the main burner.



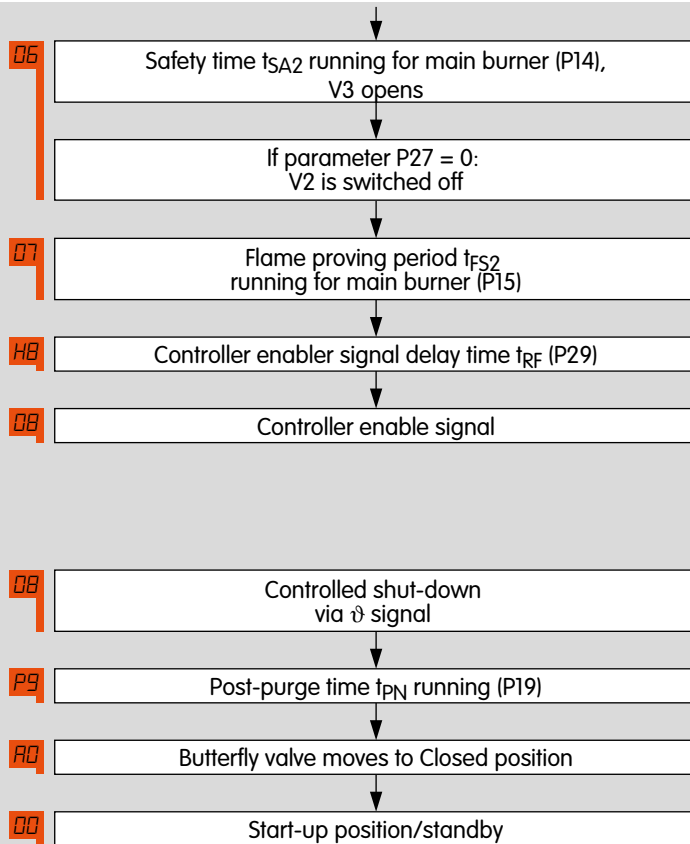

If parameter 27 = 0, V2 closes at the end of the main burner safety time t_{SA2} . The pilot burner is switched off. Then the flame proving period for the main burner t_{FS2} and the controller enable signal delay time t_{RF} start to elapse. Afterwards, the BCU issues the enable signal to the controller. If there is no pilot burner, program steps 06 and 07 will be omitted.

As soon as the start-up signal (ϑ) is switched off, post-purge starts. The butterfly valve moves to the Ignition position during this time, then to the Closed position. Next, the BCU rests in the start-up position/standby.

NOTE:

Quick start is not allowed for units with FM or CSA approval.

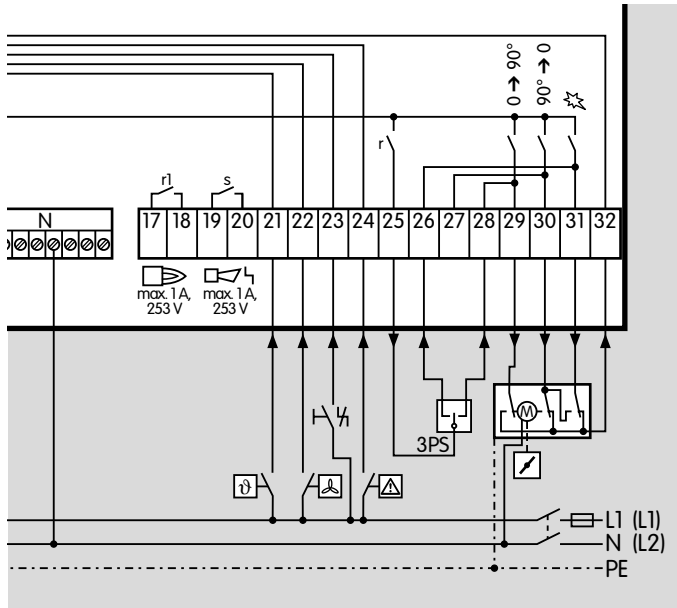

3.2.5 Controlled air flow

The controlled air flow function is enabled when the controlled air flow input, terminal 22 or via Status and fault messages for PROFIBUS DP, is activated. Cold air is fed to the combustion chamber, e.g. for cooling.

Following the air pressure switch DL “no flow” state check, the BCU 370 starts the fan and opens the butterfly valve to the Open position. The pressure switch for air DL monitors the air pressure.

If the start-up signal (ϑ) is applied during controlled air flow, the burner is started. If the elapsed controlled air flow time is at least as long as the set pre-purge time, the burner starts immediately after the Ignition position has been reached. If it is shorter, the total air volume is supplied until the end of the pre-purge time.

Activation of the controlled air flow input is not required for normal burner start.

Activation of the controlled air flow function during burner operation will be ignored.

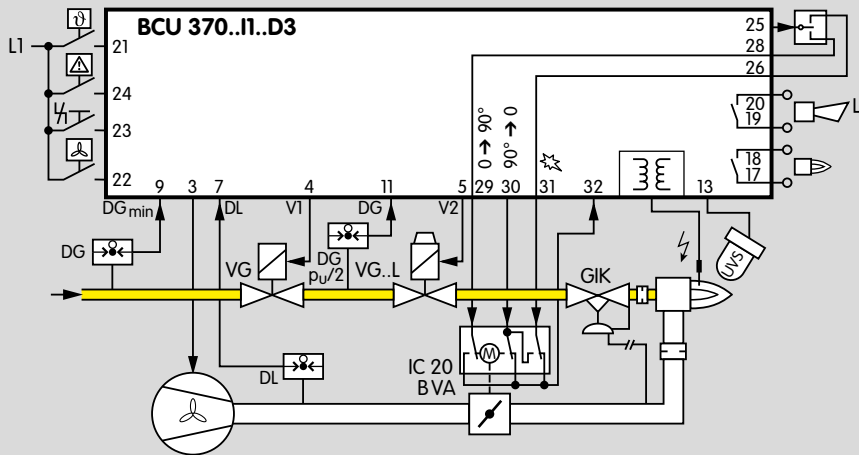

3.3 Tightness control

On BCU 370..D3, the tightness control monitors the fail-safe function of the gas solenoid valves if parameter 24 is set to 3.

The aim of the tightness control is to identify an inadmissible leak on one of the gas solenoid valves and to prevent burner start. The other gas solenoid valve continues working properly and takes over the safe shut-off of the gas supply.

The test takes place during pre-purge. The fan runs and the air pressure opens the air/gas ratio control GIK.

In the case of quick start (parameter 06 = 0), the test takes place after burner operation during post-purge. The pre- and post-purge times (parameters 18 and 19) must be set so that their duration is at least as long as the test period t_p .



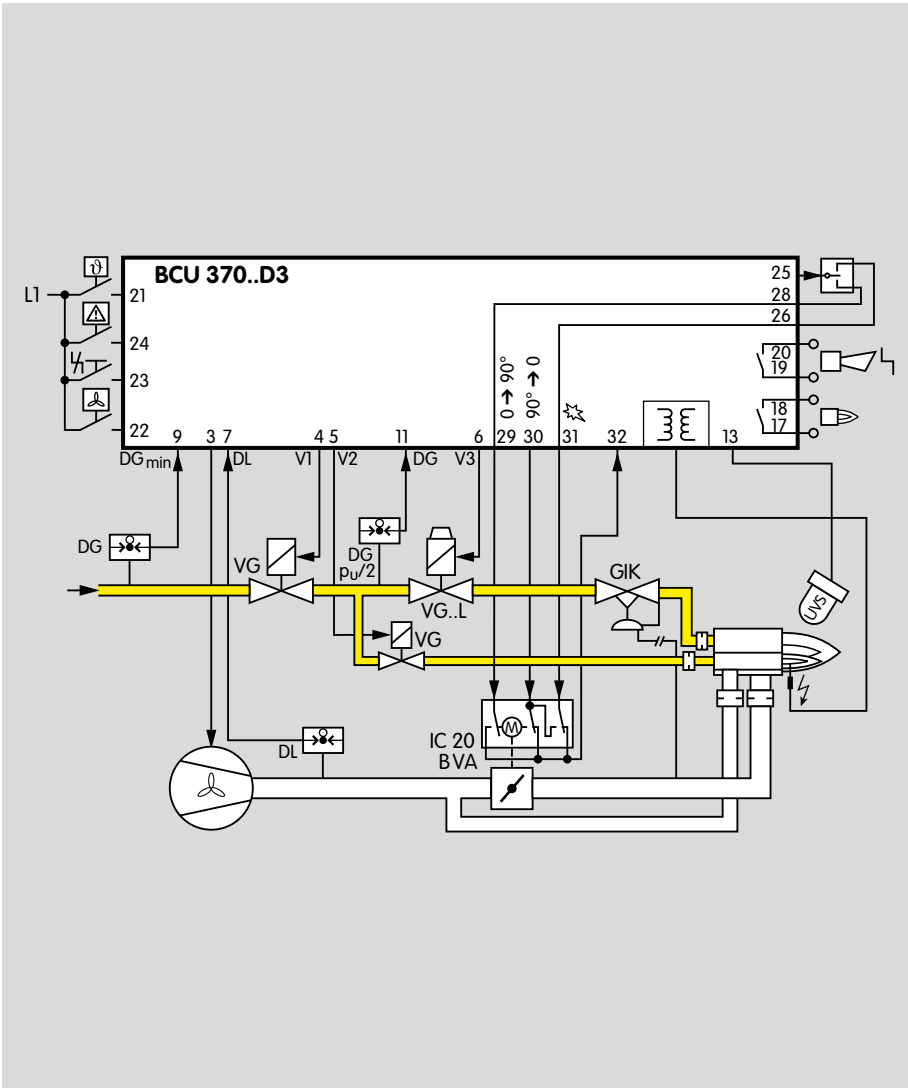

Downstream of the gas solenoid valve V2 on the burner side, the pipe to the burner must be open so that the space between valves V1 and V2 can be vented.

The pressure switch DG monitors the pressure between the two valves. It must be set to half of the inlet pressure $p_u/2$ in order to check both valves with equal sensitivity.

In pilot/main burner systems with three gas solenoid valves, V2 and V3 are checked simultaneously.

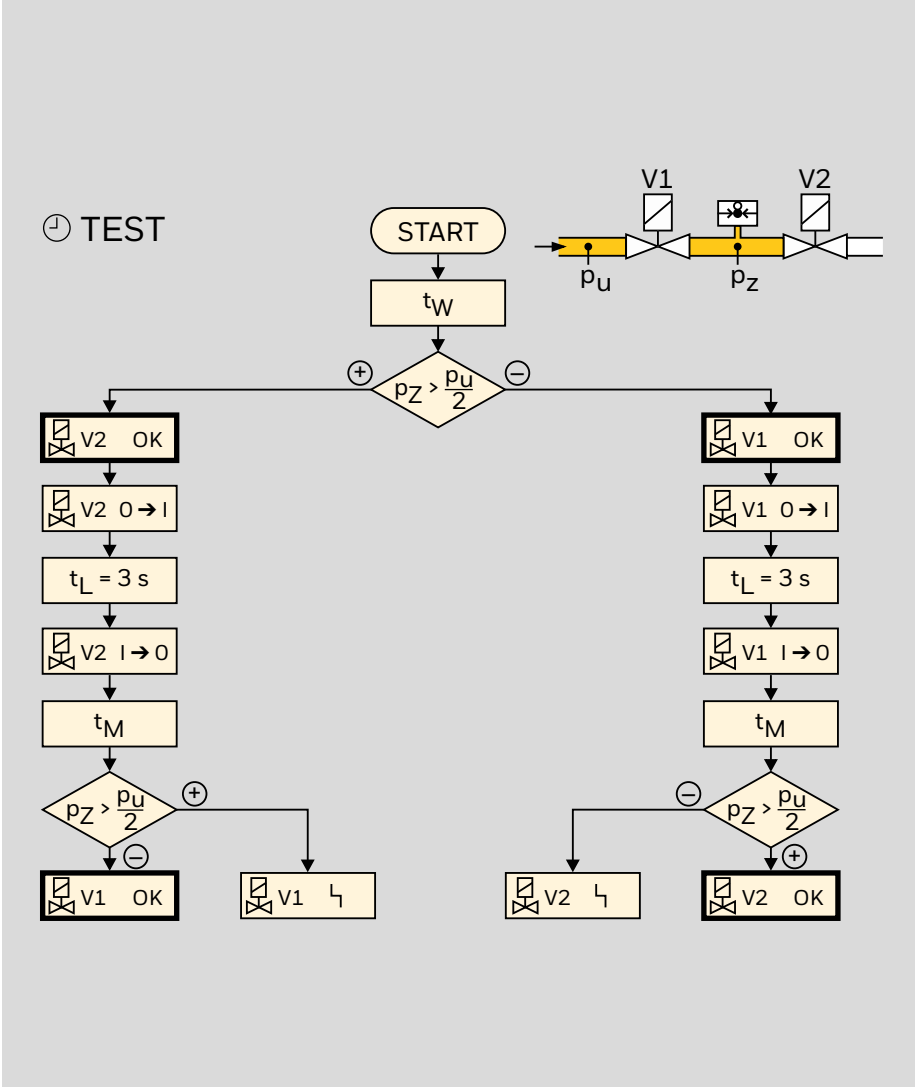

3.3.1 Program sequence

The program flow chart explains the process during the TEST phase.

After start-up the waiting time t_W starts to elapse. Then either the left or right path is executed.

- If the interspace pressure p_z is greater than half of the inlet pressure $p_u/2$ after the waiting time t_W , V2 is tight. V2 is opened for a duration of 3 seconds to vent the interspace. Then the measurement time t_M starts to elapse. If no interspace pressure can be measured after this time, V1 is also tight. Both valves have thus been checked.
- If no interspace pressure p_z can be measured after the waiting time t_W , V1 is tight. Then V1 is opened for 3 seconds to fill the space between the valves. Then the measurement time t_M starts to elapse. If a pressure can be measured in the interspace after this time, V2 is also tight. Both valves have thus been checked.



Leakage is indicated by 36 for the first valve and 37 for the second.

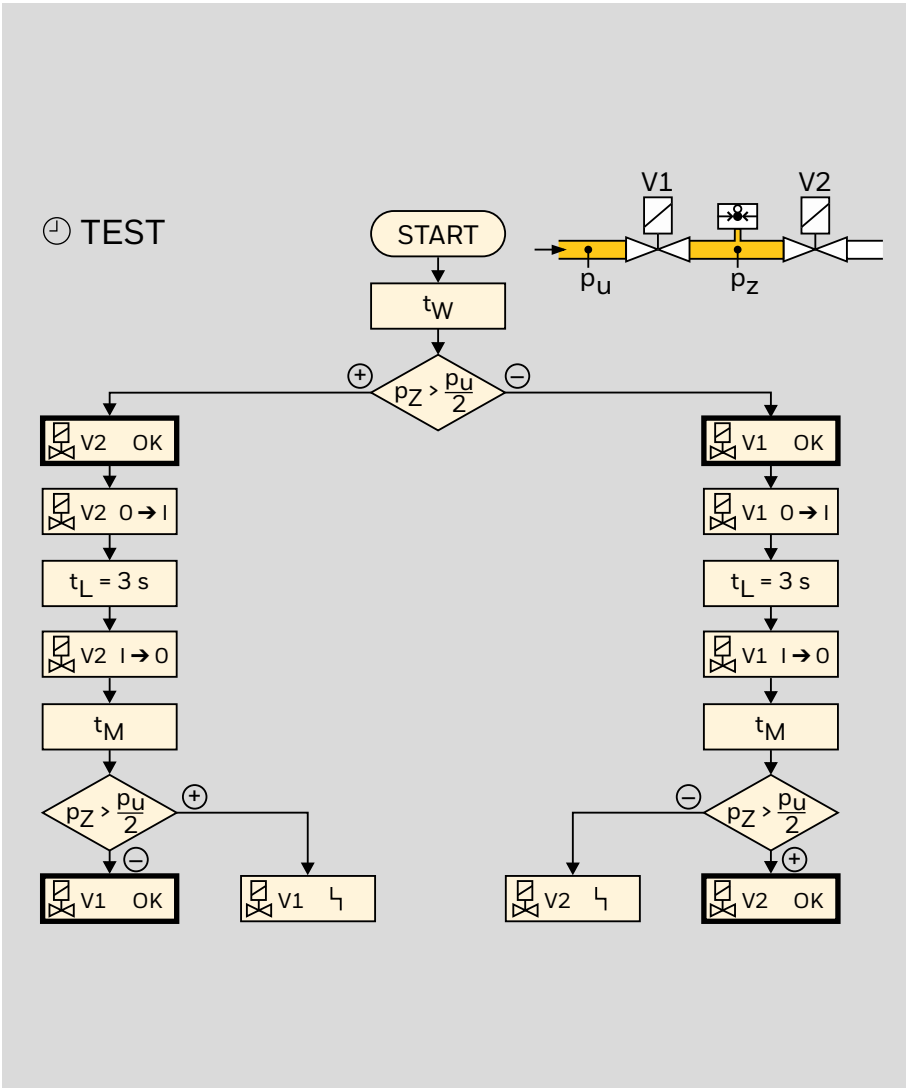

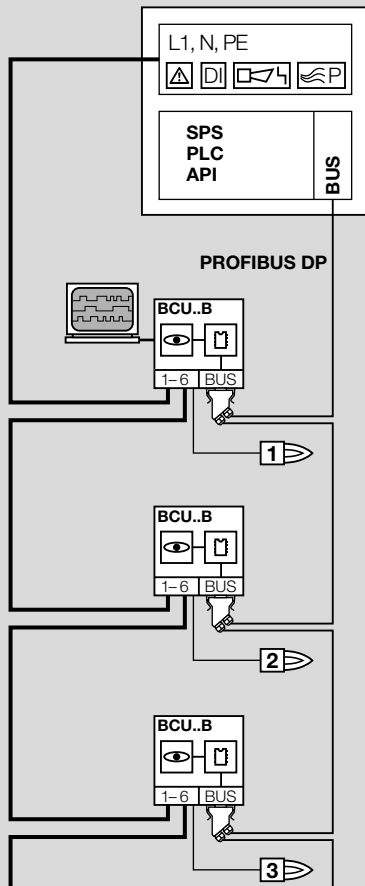

3.4 PROFIBUS DP

The BCU..B1 features the same functions and performance of a BCU[®] without a PROFIBUS connection.

PROFIBUS is a manufacturer-independent, open field-bus standard for diverse applications.

PROFIBUS DP is a bus variant for communication between automation systems and distributed peripherals at the field level, optimized for speed and low connection costs.

On PROFIBUS DP, the individual bus subscribers are connected via a 2-core shielded cable as standard.

The bus system transfers the control signals for starting, resetting and for controlling the air valve to purge the furnace or kiln or for cooling in start-up position and heating during operation from the control system (PLC) to the BCU..B1. In the opposite direction, it sends operating status, the level of the flame signal and the current program status.

3.4.1 Safety-related control signals

Signals from the safety interlocks and digital input are transferred independently of the bus communication by separate cables. The air valve used to purge the furnace or kiln can either be activated via the PROFIBUS or via a separate cable to terminal 22. The purging process must be monitored by further measures, e.g. flow monitoring.

3.4.2 BCSoft

The Windows software BCSoft allows extended access to individual statistics, protocol functions, line recorders and the parameterization of the burner control unit via an optical interface. Unit parameters which are not relevant to safety can be set and adjusted to the specific application.

3.4.3 Configuration, master-slave procedure

PROFIBUS DP is structured as a master-slave system. This allows mono-master or multi-master systems to be implemented.

A distinction is made between three device types:

- DP Master Class 1 (DPM1)
DPM1 devices are central controllers which exchange data with the distributed stations (slaves) on the basis of a defined cycle. This includes, for instance, the PLC, PC, CNC or VME systems with which the PROFIBUS DP is operated.
- DP Master Class 2 (DPM2)
DPM2 devices are programming, project planning or operator-control devices. They are used for configuration and commissioning of the system or for system operation and visualization in ongoing operation.

- DP slaves

The devices which transmit input information from the periphery to the master and which issue output information from the master to the periphery are referred to as “slaves”.

This also includes the BCU..B1.

3.4.4 Addressing

A maximum of 126 units (masters and slaves) can be connected to a PROFIBUS DP system. Each subscriber is assigned an individual PROFIBUS address which can be set between 0 and 126 using two code switches on the BCU..B1 board.

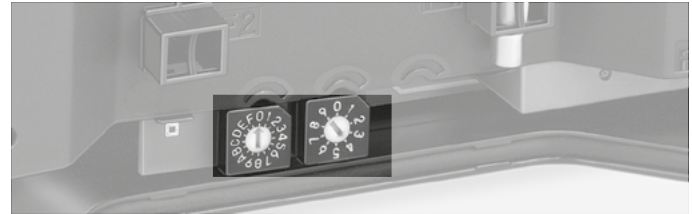

3.4.5 Network technology

All devices are connected in a bus structure (line). Up to 32 subscribers (masters or slaves) can be connected in a single segment. The beginning and end of each segment is fitted with an active bus terminator. Both bus terminators must have a permanent power supply to ensure error-free operation. The power supply for the bus terminator is provided by the BCU. The bus terminator can be connected in the bus connection plug.

If more than 32 subscribers are implemented or if there is a need to expand the network area, repeaters (amplifiers) must be used to link the individual bus segments.

3.4.6 Configuration

When planning a PROFIBUS DP system, unit-specific parameters of each subscriber are to be taken into account.

To allow for simple and standardized planning, the parameters of the BCU..B1 have been summarized in a so-called device master data file (GSD). The file structure is standardized so that it can be read by the planning devices of different manufacturers.

The GSD file can be downloaded from www.docu.thek.com, once you have registered. The steps required to copy the file are described in the instructions for the automation system.

3.4.7 Bus communication

Input bytes (BCU → master)				
Bit	Byte 0	Byte 1	Byte 2	Byte 3
0	Burner operation	Reserved	See table on page 79 (Status and fault messages for PROFIBUS DP)	0 - 25.5 µA of the burner 255 steps
1				
2	Fault lock-out			
3	Controlled air flow			
4	Open position reached*			
5	Closed position reached*			
6	ON			
7	Manual mode			

* Only on BCU 370..B1-3, three-point step control via PROFIBUS DP

Output bytes (master → BCU)	
Bit	Byte 0
0	Reset
1	Start-up
2	Controlled air flow
3	
4	
5	
6	Open*
7	Close*

* Only on BCU 370..B1-3, three-point step control via PROFIBUS DP



Function

I/O bytes: the programmer can choose the data to be transferred.

	Inputs	Outputs
BCU 370 Basic I/O	1 byte	1 byte
BCU 370 Standard I/O	4 bytes	1 byte

Baud rate: up to 1500 kbit/s.

The max. range per segment depends on the baud rate:

Baud rate [kbit/s]	Range [m]
93.75	1200
187.5	1000
500	400
1500	200

The specified ranges can be increased by using repeaters. No more than three repeaters should be connected in series.

The specified ranges relate to bus cable type A (two-core, shielded and twisted), e.g. Siemens, Order No. 6XV1830-0EH10, or Lapp cable unitronic, Order No. 2170-220T.

3.5 Program status

Display	Program status
00	Start-up position/standby
R0	Butterfly valve moves to Closed position
d0	Air monitor "no flow" state check
01	Fan run-up time t_{GV}
R1	Butterfly valve moves to Open position
d1	Air monitor operating position check
P1	Pre-purge time t_{pV}
R2	Butterfly valve moves to Ignition position
02	Waiting time t_W
03	Pre-ignition time t_{VZ}
04	1 st safety time on start-up t_{SA1}
05	1 st flame proving period t_{FS1}
06	2 nd safety time on start-up t_{SA2}
07	2 nd flame proving period t_{FS2}
H8	Controller enable signal delay time
08	Operation/Controller enable
H0	Waits for switch-on delay or min. pause time
C1	Controlled air flow
P9	Post-purge time t_{pN}

In Manual mode, two dots blink on the display.

3.6 Fault message (blinking)

Fault message (blinking)	Display	Fault lock-out	Safety shut-down	Warning signal
Flame simulation	01	●		
Start-up without flame signal	04	●		
Flame failure during 1 st flame proving period	05	●		
Flame failure during 2 nd safety time	06	●		
Flame failure during 2 nd flame proving period	07	●		
Flame failure during operation	08	●		
Too many remote resets	10	●		
Safety interlock failure	50		●	
Permanent remote reset	52			●
Timing cycle too short	53		●	
DG _{min.} oscillating	55			●
Bus module error	6E		●	
Bus fault	Pb			
Open + Close set simultaneously	56			●
Fault Valve feedback	35	●		
Tightness control: V1 leaking	36	●		
Tightness control: V2/V3 leaking	37	●		
Fault Air monitor break contact check	d0	●		
Fault Air monitor make contact check	d1	●		
Fault Air supply during pre-purge	dP	●		
Fault Air supply in program step X	dX	●		
Fault DG _{max.} in program step X	oX	●		
Fault DG _{min.} in program step X	uX		●	
Butterfly valve closed position not reached	R0	●		
Butterfly valve open position not reached	R1	●		
Butterfly valve ignition position not reached	R2	●		

3.6.1 Reaction to process faults

The BCU 370 reacts differently to process faults in different program steps. If, for example, the signal from air pressure switch DL drops during pre-purge, **d1** flashes on the display and a timeout time of 25 seconds starts to elapse. If the signal is not applied again, the BCU carries out three further start-up attempts.

Signal (terminal)	Process fault		BCU 370's reaction						
	Signal status	During program step	Controlled shut-down	Timeout 25 s	Immediate fault lock-out	Safety shut-down	Start-up attempts ¹⁾	Restart ²⁾	Fault message
DG _{max.} (11)	drops	XX All			●				oX
DG _{min.} (9)	drops	XX All except t _{SA1} + t _{SA2}				● ⁴⁾			uX
	not pending after t _{SA1}	04 t _{SA1}				● ⁴⁾			u4
	not pending after t _{SA2}	06 t _{SA2}				● ⁴⁾			u6
DL (7)	pending	d0 "no flow" state check		●	●				d0
	not pending	d1 Operating position check		●			●		d1
	drops	P1 Pre-purge time		●			●		dP
	drops	P2 Valve moves to Ignition position				●	●		d2
	drops	02 Waiting time				●	●		d2
	drops	03 Pre-ignition time				●	●		d3
	drops	04 t _{SA1}				●	●		d4
	drops	05 t _{FS1}				●	●		d5
	drops	06 t _{SA2}				●	●		d6
	drops	07 t _{FS2}				●		●	d7
	drops	H8 Controller enable waiting time				●		●	d8



Process fault				BCU 370's reaction						
Signal (terminal)	Signal status		During program step	Controlled shut-down	Timeout 25 s	Immediate fault lock-out	Safety shut-down	Start-up attempts ¹⁾	Restart ²⁾	Fault message
DL (7)	drops		Operation				●		●	
	drops		Controlled air flow		●			●		
ϕ (21)	drops		All except t _{SA1} + t _{SA2}	●						
	drops		t _{SA1}	● ³⁾						
	drops		t _{SA2}	● ³⁾						
Safety interlock (24)	drops		All				● ⁶⁾			
Flame (13)	pending		"no flow" state check		●	●				
	pending		Operating position check		●	●				
	pending		Pre-purge time		●	●				
	pending		Valve moves to Ignition position		●	●				
	pending		Waiting time		●	●				
	not pending after t _{SA1}		t _{SA1}				●	●		
	drops		t _{FS1}				●	●		
	drops		t _{SA2}				●	●		
	drops		t _{FS2}				●		●	
	drops		Controller enable waiting time				●		●	
	drops		Operation				●		●	

¹⁾ According to parameter 07. If the last start-up attempt fails, a fault lock-out occurs.

²⁾ According to parameter 08. If the restart fails, a fault lock-out occurs.

³⁾ Safety time elapses completely.

⁴⁾ BCU restarts as soon as the signal is applied again.

⁵⁾ The program sequence is blocked.

⁶⁾ 4) and 5)

4 Parameters

Description	Parameter	Value range	Default	Adjustable ¹⁾
Burner flame signal	01	0 – 25 μ A		
Burner switch-off threshold	02	1 – 20 μ A	1 μ A	○
Last fault signal	03	XX		
Air monitoring during pre-purge	04	0 = Off; 1 = On	1	●
Air monitoring during operation	05	0 = Off; 1 = On	1	●
Pre-purge	06	0 = Quick start; 1 = On each start-up	1	●
Burner start-up attempts	07	1 – 4	1	●
Restart after flame failure during operation	08	0 = Fault lock-out; 1 = Restart	0	●
Safety time during operation t_{SB}	09	1; 2 s	1 s	●
Minimum operating time t_B	10	0 – 250 s	0 s	●
Minimum burner pause time t_{BP}	11	0 – 250 s	0 s	●
1 st safety time on start-up, burner/pilot burner t_{SA1}	12	2; 3; 5; 10 s	5 s	●
1 st flame proving period, burner/pilot burner t_{FS1}	13	0; 2; 5; 10; 20 s	2 s	●
2 nd safety time on start-up, main burner t_{SA2}	14	0; 2; 3; 5; 10 s	3 s	●
2 nd flame proving period, main burner t_{FS2}	15	0; 2; 5; 10; 20 s	2 s	●
Operating time in Manual mode	16	0 = Unlimited; 1 = Limited to 5 minutes	1	●
UVS check (1× in 24 hours)	17	0 = Off; 1 = On	0	●
Pre-purge time t_{PV}	18	0 – 250 s	30 s	●
Post-purge time t_{PN}	19	0 – 250 s	0 s	●
Fan run-up time t_{GV}	20	0 – 25 s	2 s	●



Parameters

Description	Parameter	Value range	Default	Adjustable ¹⁾
Pre-ignition time t_{VZ}	21	0 – 5 s	1 s	●
Switch-on delay time t_E	22	0 – 250 s	0 s	●
Min. gas pressure monitoring	23	0 = Off; 1 = On	1	●
Digital input function	24	0 = – 1 = DG_{max} . 3 = Tightness control	1	○
Valve control	25	0 = Off; 1 = On	1	●
Tightness controll, test period t_p	26	10; 20; 30 – 250 s	10 s	○
V2 during burner operation	27	0 = Off; 1 = On	0	●
Quick start starts in...	28	0 = Ignition position; 1 = Closed position	0	●
Controller enable signal delay time t_{RF}	29	0; 10; 20; 30 – 250 s	0 s	●
User-defined password	30	0000 – 9999	XXXX	● ²⁾
Bus control activation	31	0 = Off; 1 = On	1	○
Bus control limitation	32	0 = Closed position 1 = Low position 2 = Ignition position	2	○
The last 10 fault messages	81 – 90	XX		

¹⁾ Adjustable using BCSoft software and a PC opto-adapter. Changes using BCSoft must be verified by scanning the parameters using the Reset/Information button.

²⁾ Will not be displayed.

● = Adjustable

○ = Depends on hardware configuration

4.1 Scanning the parameters

During operation, the 7-segment display shows the program step/status.

In addition to the flame signal and the fault history, all the parameters of the BCU can be scanned in numerical order by repeatedly pressing the Reset/Information button (for 1 s).

The parameter display is ended 60 seconds after the last time the button is pressed or by switching off the BCU.

The BCU displays  when the mains switch is off.

The parameters cannot be scanned when the BCU is switched off or when a fault or warning is displayed.

4.2 Flame control

The BCU is fitted with a flame amplifier which evaluates whether an adequate flame signal is supplied by the burner using a flame rod or UV sensor.

4.2.1 Burner flame signal

Parameter 01

Displays the flame signal in μA .

The BCU measures the flame signal and assesses whether there is a flame on the basis of the switch-off threshold.

4.2.2 Burner switch-off threshold

Parameter 02

The sensitivity at which the burner control unit detects a flame can be set using parameter 02.

As soon as the measured flame signal falls below the set value (2 to 20 μA), the BCU performs a fault lock-out during start-up after the elapse of the safety time or during operation after the elapse of the safety time during operation (parameter 19).

In the case of UV control, this value can be increased, should the burner to be monitored be influenced by other burners for example.

The measured flame signal of the system's "own" burner should be at least 3 μA (empirical value) higher than the set switch-off threshold.

No switch-off threshold will be displayed on the BCU 370..U1 for use with UVC 1.

4.2.3 UVS check (1× in 24 hours)

Parameter 17

Activates an automatic restart of the burner control unit after 24 hours operating time.

For flame control using a UV sensor for intermittent operation, parameter P17 = 1 must be set to force a restart after 24 hours of operation to test the UV sensor.

Parameter 17 = 0: unlimited burner operation

Parameter 17 = 1: an automatic restart is activated once every 24 hours. The restart begins with pre-purge (parameter 06, “Pre-purge on each start-up” = 1) or starting the burner in the Ignition position (parameter 06, “Pre-purge on each start-up” = 0).

The time starts each time the start-up signal (9) is applied.

Since the BCU 370 interrupts burner operation autonomously after 24 hours, it is to be verified whether the process allows for the resulting break in heat supply.

4.3 Behaviour during start-up

4.3.1 Minimum burner pause time t_{BP}

Parameter 11

Determines the minimum burner pause time.

To stabilize the burner operation, a minimum burner pause time t_{BP} can be set independently of the central control system.

If the start-up signal (9) drops after fan start or if a safety shut-down occurs, a restart is suppressed for the duration of the minimum burner pause time t_{BP} , which starts to elapse after expiry of the post-purge time t_{PN} (parameter 19).

4.3.2 Burner start-up attempts

Parameter 07

This defines the maximum number of possible start-up attempts of the burner.

For burners which require several start-up attempts due to longer pipes for example, the BCU can automatically carry out several start-up attempts.

Parameter 07 = 1: one start-up attempt

If a safety shut-down takes place during start-up, e.g. on account of a flame signal failure, a fault lock-out occurs once the time t_{SA} has elapsed. The display blinks and shows the cause of the fault.

Parameter 07 = 2 – 4: 2 – 4 start-up attempts

If several start-up attempts are set at the works and if the BCU performs a safety shut-down during start-up, it closes the valves after the safety time t_{SA} has expired and attempts to start up again. Each start-up attempt begins with pre-purge. Once the last programmed start-up attempt has failed, the burner control unit performs a fault lock-out, in case no flame has formed. The display blinks and shows the cause of the fault.

In accordance with EN 746-2 and EN 676 a maximum of four start-ups are permitted in specific cases if the safety of the installation is not impaired. Please note application standards.

NOTE: only 1 start-up attempt is possible for units with FM or CSA approval.

4.3.3 Switch-on delay time t_E

Parameter 22

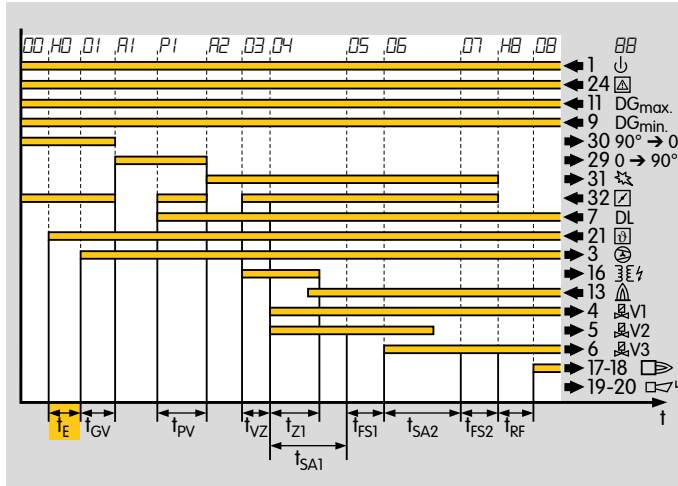

Determines the time between applying the start-up signal (θ) and initiating the burner start.

When several burners are activated simultaneously, setting different switch-on delay times t_E prevents the fans from starting at the same time and reduces the load on the power supply.

4.3.4 Pre-ignition time t_{VZ}

Parameter 21

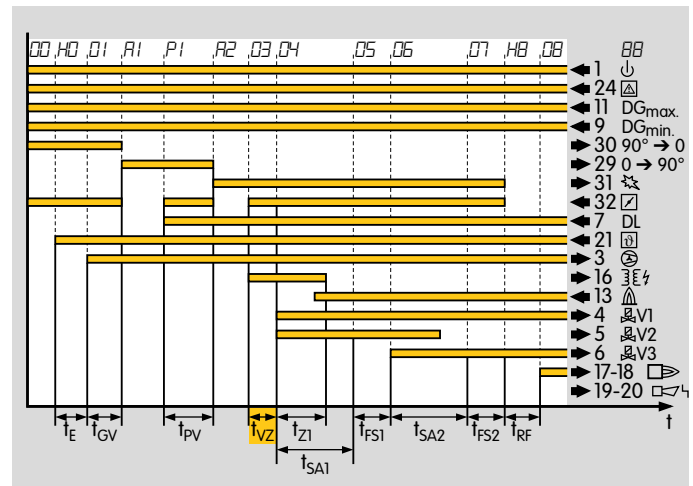

The ignition unit is activated.

The ignition spark can stabilize in the air flow during the pre-ignition time t_{VZ} .

The valves are still closed during the pre-ignition time t_{VZ} . Following pre-ignition t_{VZ} , the safety time t_{SA1} starts to elapse. The valves are opened while the ignition unit continues to operate.

4.3.5 1st safety time on start-up, burner/pilot burner t_{SA1}

Parameter 12

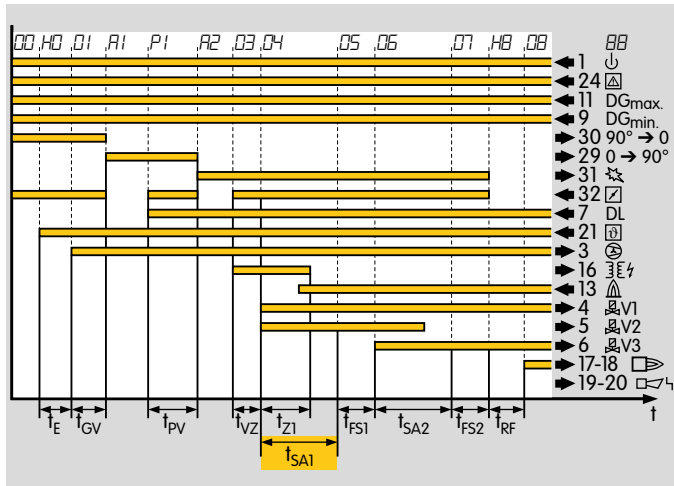

The safety time on start-up t_{SA1} determines when the pilot burner or burner valves will be closed in the event of flame signal failure.

V1 and V2 are opened and the ignition unit is activated as the safety time t_{SA1} starts to elapse. If no flame signal is pending after elapse of the safety time t_{SA1} , the BCU performs a safety shut-down. The valves are closed. The BCU carries out up to 3 further start-up attempts, depending on how parameter 07 “Burner start-up attempts” has been set.

The setting of safety time t_{SA1} is to be determined on the basis of the burner capacity, the type of control and the relevant application standard, e.g. EN 746-2, EN 676, NFPA 85 or NFPA 86.

4.3.6 1st flame proving period, burner/pilot burner t_{FS1}

Parameter 13

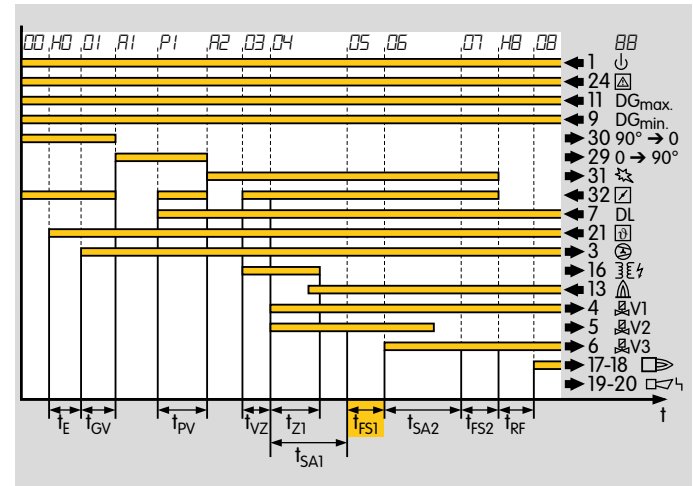

Determines the flame proving period of the burner or pilot burner.

This time elapses before the BCU starts the next program step so as to give the flame time to stabilize.

The flame proving period t_{FS1} starts to elapse once safety time t_{SA1} has expired.

4.3.7 2nd safety time on start-up, main burner t_{SA2}

Parameter 14

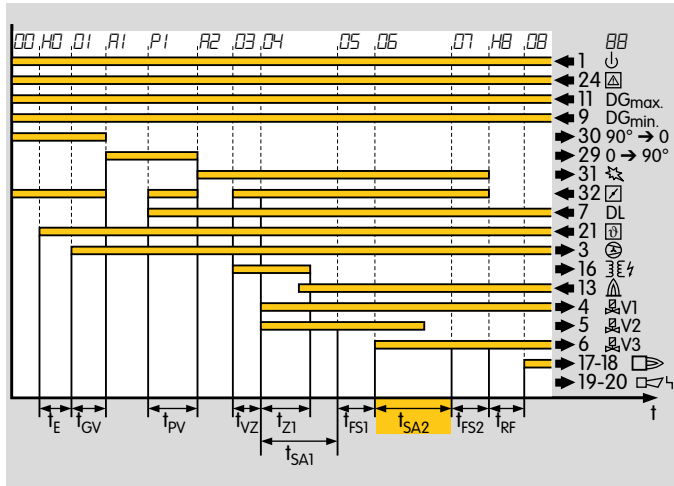

The safety time on start-up t_{SA2} determines when the main burner valves will be closed in the event of flame signal failure.

V3 is opened as the safety time t_{SA2} starts to elapse. One second before the end of the safety time t_{SA2} , V2 is closed (parameter 27 = 0, "Interrupted pilot burner") or remains open (parameter 27 = 1, "Permanent pilot burner"). If no flame signal is pending after elapse of the safety time t_{SA2} , the BCU performs a safety shutdown. Valves V1, V2 and V3 are closed. The BCU carries out up to 3 further start-up attempts, depending on how parameter 07 "Burner start-up attempts" has been set.

The setting of safety time t_{SA2} is to be determined on the basis of the burner capacity, the type of control and the relevant application standard, e.g. EN 746-2, EN 676, NFPA 85 or NFPA 86.

4.3.8 2nd flame proving period, main burner t_{FS2}

Parameter 15

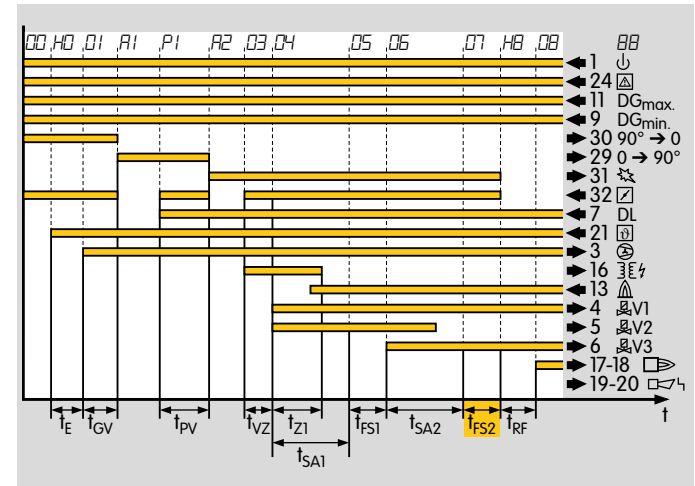

Determines the flame proving period of the main burner in pilot/main burner combinations.

This time elapses before the BCU starts the next program step so as to give the flame time to stabilize.

The flame proving period t_{FS2} starts to elapse once safety time t_{SA2} has expired.

4.4 Behaviour during operation

4.4.1 Minimum operating time t_B

Parameter 10

Defines the minimum burner operating time.

To stabilize the burner operation, a minimum operating time can be set independently of the central control system.

If the start-up signal (9) drops once the first safety time t_{SA1} has started to elapse, the burner remains in operation for at least time t_B . The minimum operating time t_B starts to elapse following controller enable. If the start-up signal drops before the first safety time t_{SA1} , e.g. during pre-purge, the control unit reverts directly to standby and the burner is not ignited.

4.4.2 Controller enable signal delay time t_{RF}

Parameter 29

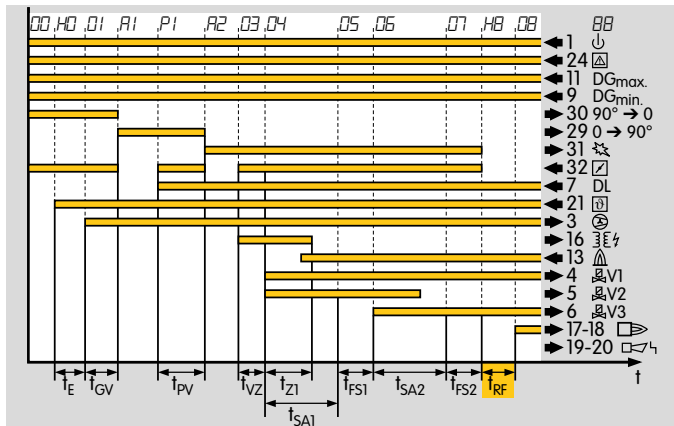

Defines the time between start-up of the burner and controller enable.

The controller enable signal delay time ensures a stable combustion process, e.g. through uniform heating of the entire combustion chamber.

The time t_{RF} starts to elapse

after expiry of	if
t_{SA1}	$t_{FS1} = 0, t_{SA2} = 0$
t_{FS1}	$t_{SA2} = 0$
t_{SA2}	$t_{FS2} = 0$
t_{FS2}	$t_{FS1} > 0, t_{SA2} > 0, t_{FS1} > 0$

The BCU shows program status **HB**. After time t_{RF} has elapsed, the BCU closes the operation signalling contact (terminals 17/18) and activates controller enable (terminal 25).

4.4.3 Safety time during operation t_{SB}

Parameter 09

Defines the safety time during operation t_{SB} for valves V1, V2 and V3.

If there is a flame failure while the burner is operating, the BCU closes the valves within the safety time during operation t_{SB} . The default in accordance with EN 298 is 1 s. The safety time during operation t_{SB} can also be set to 2 s. Prolonging the time increases the installation availability in the case of brief-duration fades of the flame signal.

The safety time of the installation during operation (including closing time of the valves) may not exceed 3 s in accordance with EN 746-2 or 4 s in accordance with NFPA 85 and NFPA 86. Please note application standards.

4.4.4 Restart after flame failure during operation

Parameter 08

Determines whether a restart will be attempted following a safety shut-down during operation.

For burners with occasionally unstable flame signals during operation, a one-off restart can be attempted.

Parameter 08 = 0: Off. A fault lock-out will occur in the event of a flame failure during operation

In the event of an installation fault (e.g. flame failure or air pressure failure), the burner control unit performs a fault lock-out within the safety time during operation t_{SB} . This involves disconnecting the power from the gas valves. The fault signalling contact closes, the display blinks and shows the current program status, see page 79 (Status and fault messages for PROFIBUS DP).

Parameter 08 = 1: On. A restart will take place after a flame failure during operation.

If the BCU detects an installation fault (e.g. flame failure) after the second flame proving period has elapsed, the valves are closed and the operation signalling contact is opened within time t_{SB} . The burner control unit now attempts to restart the burner once. The restart begins with pre-purge. For further restart attempts, the burner must have been operational for at least 2 seconds.

If the burner does not function, a fault lock-out occurs. The display blinks and shows the cause of the fault.

In accordance with EN 746-2 and EN 676, a restart may be attempted under certain conditions. The safety of the system must not be impaired. Please note application standards.

4.4.5 Last fault signal

Parameter 03

The BCU shows the last fault message.

In order to analyze a burner system, the last fault message can be called up. In addition, parameters 81 to 90 show the last 10 messages. Extended diagnostics is possible using the BCSoft software.

4.4.6 V2 during burner operation

Parameter 27

Determines whether valve V2 is switched off 1 s before the end of the second safety time t_{SA2} .

On systems with pilot burners, the pilot burner can be switched off once the main burner is operational.

Parameter 27 = 0: valve V2 is switched off 1 s before the end of the second safety time t_{SA2} . (If t_{SA2} is set to 0, this occurs at the end of the first flame proving period t_{FS1} or at the end of the first safety time t_{SA1} if $t_{FS1} = 0$).

This setting is required for pilot/main burner systems where the pilot burner does not ignite the main burner safely in each operating status.

Parameter 27 = 1: valve V2 remains open during the entire burner operation. This setting is valid for directly ignited burners ($t_{SA2} = 0$) and pilot/main burner systems with permanent pilot burner.

4.5 Monitoring/tightness control

4.5.1 Min. gas pressure monitoring

Parameter 23

Determines whether the minimum gas pressure DG_{min} is monitored.

To ensure that there is adequate gas pressure on the burner, the pressure can be monitored using the gas pressure monitor DG_{min} .

Monitoring takes place in the start-up position/standby, during burner start-up or during burner operation. If the signal is not applied, a locking warning signal is triggered and the display shows $\square X$, "Fault DG_{min} in program step X". When the signal is applied again, the BCU 370 attempts to restart the burner, provided the start-up signal (ϑ) is applied.

The requirement for monitoring of the minimum gas pressure is stipulated in the relevant application standard.

4.5.2 Digital input function

Parameter 24

Defines the function of the input on terminal 11.

Parameter 24 = 0: input has no function.

Parameter 24 = 1: monitoring of the maximum gas pressure DG_{max} .

To ensure that the permissible gas pressure on the burner is not exceeded, the pressure can be monitored using the gas pressure monitor DG_{max} .

Monitoring takes place in the start-up position/standby, during burner start-up or during burner operation. If the signal is not applied, a fault lock-out occurs and the display shows $\square X$, "Fault DG_{max} in program step X".

Parameter 24 = 3: monitoring of the pressure switch between V1 and V2/V3 for tightness control (only on BCU..D3). See Function – Tightness control.

4.5.3 Air monitoring during pre-purge

Parameter 04

This parameter is activated automatically if parameter 05 “Air monitoring during operation” has also been activated. The parameter determines whether the air supply is monitored during pre-purge.

To ensure that there is actually air pressure during pre-purge, the pressure can be monitored using the air monitoring during pre-purge function.

Parameter 04 = 0: no air monitoring during pre-purge. A decrease in the air pressure or a failure in air supply will not be detected.

Parameter 04 = 1: air monitoring during pre-purge. Air pressure switch signal to terminal DL (7). The BCU checks whether the air monitor signal changes:

- Check of the LOW signal (no air monitoring signal)
Before pre-purge, no signal may be present. A LOW signal must be applied to input DL. If the LOW signal is not applied, the BCU performs a fault lock-out once the delay time of 25 seconds has elapsed. Fault message: **[dD]**, “no flow” state check.
- Check of the HIGH signal (air monitoring signal activated)
Once the fan has been activated, the BCU checks whether the air monitor switches while the actuator moves to the Open position (start-up with pre-purge) or during the waiting time (quick start). The signal to input DL must be switched to HIGH. If the HIGH sig-

nal is not applied, the BCU performs the set number of further start-up attempts (parameter 07) after a delay time of 25 seconds has elapsed. If no further start-up attempts have been parameterized, a fault lock-out occurs and fault message **[dI]**, “No air supply during start-up”, is displayed.

Air pressure must be present and a HIGH signal must be applied to input DL during the subsequent pre-purge. If the HIGH signal is not applied, the BCU performs a safety shut-down once the delay time of 25 seconds has elapsed. If no further start-up attempts have been parameterized (parameter 07), a fault lock-out occurs and fault message **[dP]**, “No air supply during pre-purge”, is displayed.

Depending on the application standard, different air monitoring methods are possible. Along with pressure monitoring, other functions such as fail-safe feedback signals from the actuator or air flow monitoring devices may be required. Please note application standards.

4.5.4 Air monitoring during operation

Parameter 05

If this parameter is activated, parameter 04 “Air monitoring during pre-purge” is also activated. This parameter determines whether the air supply is monitored during burner operation.

To ensure that there is actually air pressure during burner operation, the pressure can be monitored using the air monitoring during operation function.

Parameter 05 = 0: no air monitoring during operation. A decrease in the air pressure or a failure in air supply will not be detected.

Parameter 05 = 1: the air pressure is monitored during operation. During burner start (after pre-purge until the end of the main burner safety time t_{SA2}) and during burner operation (after the end of main burner flame proving period t_{FS2} until the end of normal operation), the air must flow and a HIGH signal must be applied to input DL. If the HIGH signal drops, the BCU performs a safety shut-down.

- DL signal drops during burner start.
If further start-up attempts have been parameterized (parameter 07), a further burner start-up attempt is made. If no further start-up attempts have been parameterized, a fault lock-out occurs and fault message \boxed{dX} , “No air pressure on DL in program step X”, is displayed.
- DL signal drops during burner operation.
If a restart is parameterized (parameter 08), a one-off burner restart is attempted. If the restart option is not activated, a fault lock-out occurs and fault message \boxed{dX} , “No air pressure on DL in program step X”, is displayed.

4.5.5 Tightness controll, test period t_P

Parameter 26

BCU..D3 only

Defines the tightness control test period t_P for the gas solenoid valves. It can be set to 10, 20 or 30 to 250 seconds.

Depending on the burner capacity, the tightness of the gas solenoid valves must be checked in accordance with the relevant application standard, e.g. EN 676, EN 746, NFPA 85 and NFPA 86.

The sensitivity of the tightness control can be adjusted individually by adapting the test period t_P . If a low leakage rate Q_L is to be detected, a long test period t_P must be set. The test period t_P is the sum of the waiting time t_W , 3 s opening time t_L and measurement time t_M . The test period t_P is calculated from the inlet pressure p_U [mbar (psig)], the leakage rate Q_L [L/h (ft³/h)] and the test volume V_P [l (ft³)].

$$t_P = 4 \times \left(\frac{p_U \text{ [mbar]} \times V_P \text{ [l]}}{Q_L \text{ [L/h]}} + 1 \text{ s} \right)$$

Leakage rate

The tightness test allows a check to be made for a specific leakage rate Q_L . In countries where the standards and Directives of the European Union are applicable, the maximum leakage rate Q_L is 0.1% of the maximum flow rate $Q_{(N) \text{ max.}}$ [m³(ft³)/h (n)].

$$\text{Leakage rate } Q_L \text{ [L/h]} = \frac{Q_{(N) \text{ max.}} \text{ [m}^3\text{/h]} \times 1000 \text{ [L/h]}}{1000 \times 1 \text{ [m}^3\text{/h]}}$$

Test volume V_P

The test volume V_P is calculated from the basic volume V_G (for 2 valves V_G), added to the volume of the pipe V_M for each additional metre in length L :

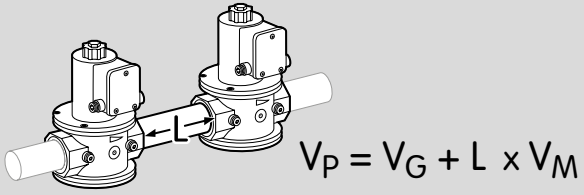

DN	Basic volume V_G		Volume per metre V_M	
	Litres	Quarts	Litres	Quarts
10	0.01	0.011	0.1	0.11
15	0.07	0.074	0.2	0.21
20	0.12	0.127	0.3	0.32
25	0.2	0.21	0.5	0.53
40	0.7	0.74	1.3	1.37
50	1.2	1.27	2	2.11
65	2	2.11	3.3	3.49
80	4	4.23	5	5.28
100	8.3	8.77	7.9	8.35
125	13.6	14.37	12.3	13
150	20	21.13	17.7	18.7
200	42	44.38	31.4	33.18

4.6 Air control

4.6.1 Valve control

Parameter 25

Determines whether an actuator connected to terminals 29 to 32 is activated for valve control.

If valve control is deactivated, the BCU 370 can be used to control single-stage-controlled burners.

Parameter 25 = 1: valve control is active. The BCU activates the outputs on terminals 29, 30 and 31 to move the actuator to the Open (pre-purge), Closed and Ignition positions. When the appropriate position is reached, this information is signalled back by the actuator via the input on terminal 32. The BCU 370 waits for the feedback signal from the actuator once the outputs have been activated. The time required depends on the actuator running time. If the position is not reached within the timeout time of 250 seconds, the BCU displays the fault message "Position not reached".

Parameter 25 = 0: the BCU 370 runs through all program steps without waiting for a feedback signal from the butterfly valve. The outputs for valve control are not activated.

4.6.2 Pre-purge

Parameter 06

This parameter determines whether the BCU pre-purges on the next start-up after a controlled shut-down.

Within the scope of the application standard EN 676 pre-purge can be dispensed with under certain conditions. This prevents cold air from entering the combustion chamber and accelerates burner start-up.

Parameter 06 = 1: pre-purge occurs on each start-up.

Parameter 06 = 0: pre-purge is omitted if the last shut-down was a controlled shut-down and occurred within the last 24 hours. After switching on the BCU, after a safety shut-down or a fault lock-out or after a pause of more than 24 hours, the BCU completes an entire pre-purge cycle.

For burner capacities as from 70 kW, application standard EN 676 requires that a valve check be carried out if pre-purge has been omitted.

For burner capacities as from 117 kW, application standards NFPA 85 and NFPA 86 require a valve check before pre-purge and a pre-purge before each system start.

The valves can be checked using a tightness control. See "Function – Tightness control". Please note application standards.

4.6.3 Quick start starts in...

Parameter 28

Only active if parameter 06 = 0 (Pre-purge) and parameter 25 = 1 (Valve control) are set.

Determines whether on quick start, the butterfly valve rests in the Ignition position or in the Closed position during standby.

In the Closed position, the amount of combustion air which enters the combustion chamber is minimized.

Parameter 28 = 0: the BCU sets the butterfly valve to the Ignition position for quick start after controlled shut-down. Once the start-up signal (9) has been applied, the BCU initiates burner ignition immediately after the fan run-up time (parameter 20) and the waiting time.

Parameter 28 = 1: the BCU sets the butterfly valve to the Closed position for quick start after controlled shut-down. Once the start-up signal (9) has been applied, the BCU moves the actuator to the Ignition position via the Open position and ignites the burner after the fan run-up time (parameter 20) and the waiting time. The time between activating the start-up signal (9) and burner start is determined by the running time of the actuator of the butterfly valve.

4.6.4 Pre-purge time t_{PV}

Parameter 18

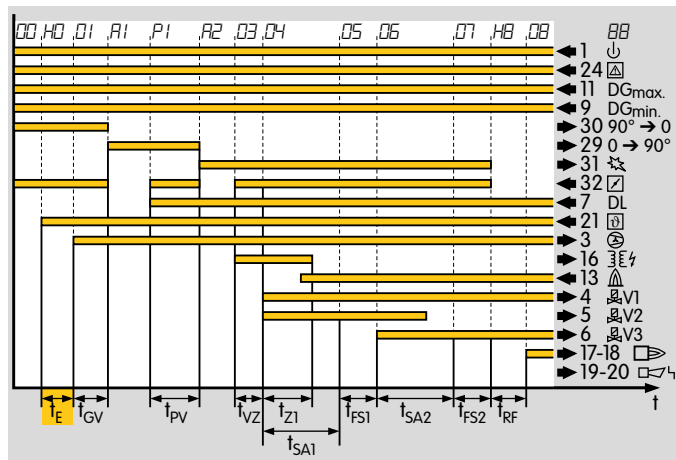

Determines how long the full air flow will be supplied to the combustion chamber before burner start.

Pre-purge removes non-combusted gases from the combustion chamber.

The pre-purge time t_{PV} starts once the actuator has signalled the Open position and the air pressure switch DL contact has closed.

If “Pre-purge on each start-up” is deactivated (parameter 06 = 0), pre-purge is omitted on burner start after a controlled shut-down within the last 24 hours.

If the pre-purge time t_{PV} is set to 0 s, pre-purge is always omitted, e.g. even on restart after a safety shut-down. The BCU carries out a quick start on each burner

start. The butterfly valve is moved to the Ignition position via the Open position after controlled shut-down.

If tightness control is activated (BCU..D3, parameter 24 = 3), the pre-purge time t_{PV} must be set to at least the value of the test period (parameter 26).

The pre-purge time t_{PV} is to be set on the basis of the relevant application standard (e.g. EN 676, EN 746-2, NFPA 85 or NFPA 86).

4.6.5 Post-purge time t_{PN}

Parameter 19

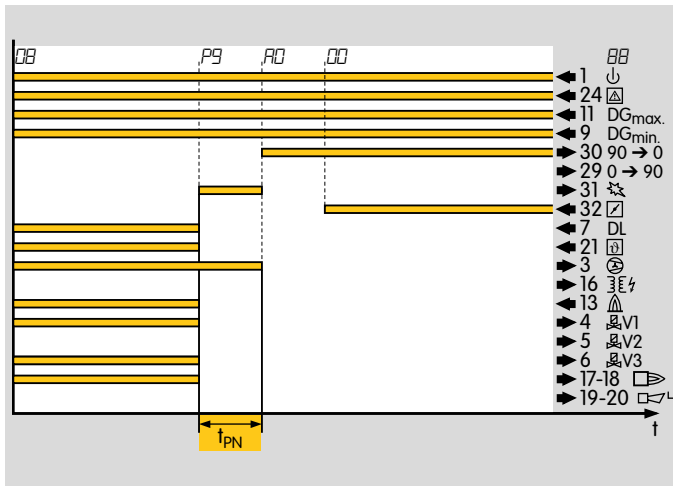

Determines how long air will be supplied to the combustion chamber after burner operation has been terminated.

To remove combustion gas residues from the burner, this can be purged with air after operation.

The post-purge time t_{PN} starts to elapse once the start-up signal (\uparrow) has been deactivated or once the first safety time has elapsed in case of a safety shut-down.

If the actuator is located above the Ignition position at this time, it moves to the Ignition position. If it is below the Ignition position, the actuator stays in its current position.

Pre-purge on each start-up (parameter 06 = 1):
The actuator moves to the Closed position after the end of the post-purge time t_{PN} .

Quick start (parameter 06 = 0) or pre-purge time = 0 (parameter 18 = 0):

After the post-purge time t_{PN} has elapsed, the actuator moves to the Open position and then to the Ignition position (parameter 28 = 0) or the Min position (parameter 28 = 1).

If tightness control is activated (BCU..D3, parameter 24 = 3) and quick start is activated (parameter 06 = 0), the post-purge time must be set to at least the value of the test period (parameter 26).

4.6.6 Fan run-up time t_{GV}

Parameter 20

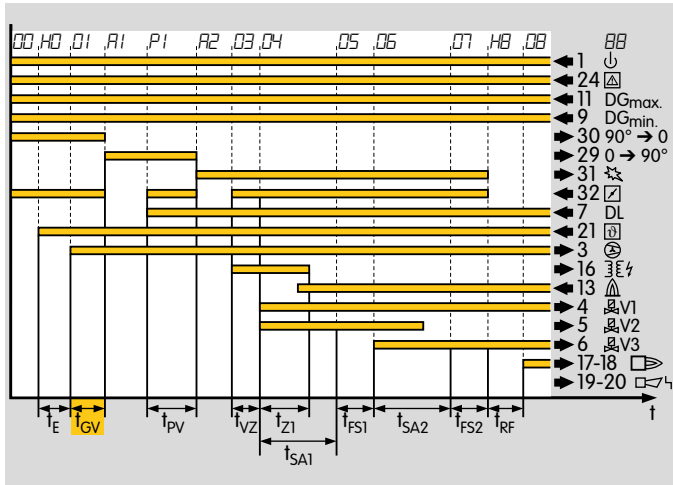

This parameter defines the time between the activation of the fan output (terminal 3) and the opening of the butterfly valve or burner start.

Fan start with the butterfly valve being closed reduces the start-up current of the fan motor.

4.7 Control using PROFIBUS DP

4.7.1 Bus control activation

Parameter 31

Only on BCU 370..B1-3

Activates three-point step control via Profibus DP.

The activation signals for capacity control using the butterfly valve can be transferred via the Profibus DP. Once bit 7 of the output byte has been set, the valve moves in the direction of the Closed position. When bit 6 is set, the valve moves to the Open position. If both bits are set, the valve stops. The BCU 370 displays fault message **55**, "Open + Close set simultaneously".

The lower limit of the modulation range is defined using parameter 32.

4.7.2 Bus control limitation

Parameter 32

Only on BCU 370..B1-3

Defines the lower limit of the modulation range of the butterfly valve.

Parameter 32 = 0: when bit 7 is activated, the butterfly valve moves to the Closed position. This is defined by the limit switch in the actuator.

Parameter 32 = 2: when bit 7 is activated, the butterfly valve moves to the Ignition position. This is defined by the limit switch in the actuator.

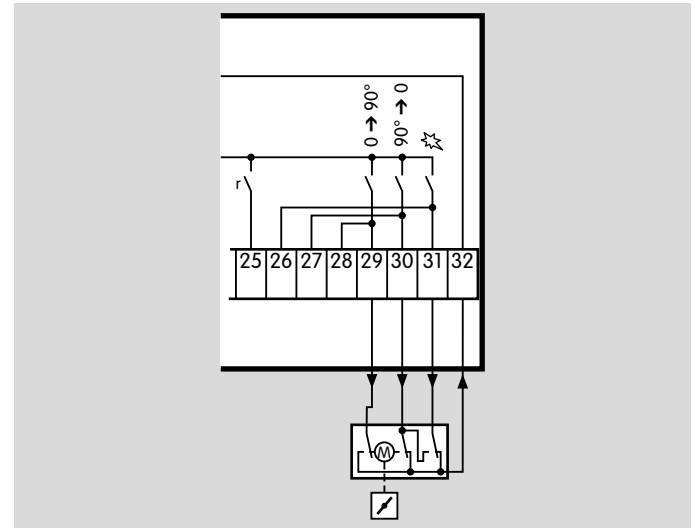

Parameters

Parameter 32 = 1: when bit 7 is activated, the butterfly valve moves to the Low position. For this purpose, terminal 25 is wired to a fourth limit switch in the actuator.

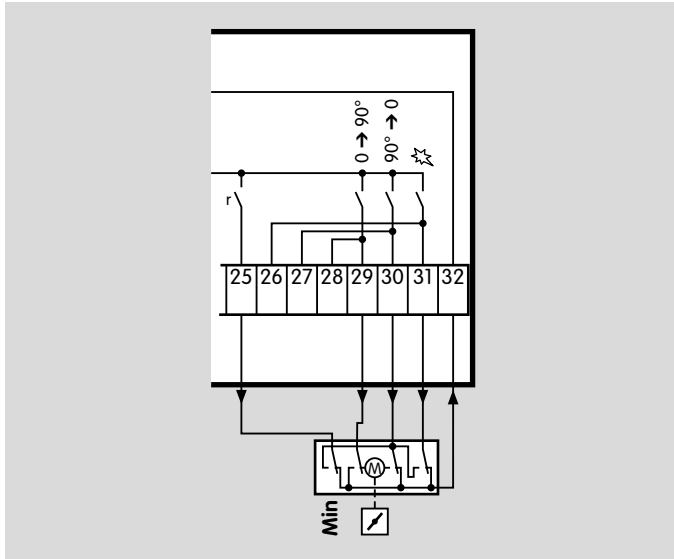

Definition of the modulation range following controller enable

BCU..B1-3 with three-point step control function

Valve position	Output byte
Upper end position Open	Bit 6
Lower end position Closed	Bit 7, parameter 32 = 0
Lower end position Low	Bit 7, parameter 32 = 1, terminal 25 wired to separate limit switch
Lower end position Ignition	Bit 7, parameter 32 = 2

4.8 Manual mode

For convenient setting of the burner or analyzing faults.

If the Reset/Information button is pressed for 2 s during switch-on, the BCU reverts to Manual mode. Two dots blink on the display.

In this operating mode, the burner control unit operates independently of the status of the inputs Start-up signal (S) (terminal 21), Controlled air flow (terminal 22) and Remote reset (terminal 23) as well as the bus inputs on BCU.B1. The functions of the safety interlock (terminal 24) are retained.

Each time after the button is pressed again, the BCU moves to the next section of the program sequence and stops there. After approx. 3 seconds, the flame signal is indicated instead of the operating status. In the event of flame simulation, the flame signal will be displayed immediately.

Following controller enable (status display **OB**), a connected butterfly valve can be opened and closed as required. By holding the button, the motor is first opened further. The BCU indicates **R.I.**, with blinking dots. Once the button has been released, the butterfly valve stops in the relevant position. If the button is pressed again, the butterfly valve is closed (Closed position). The BCU indicates **R.C.**, with blinking dots. A change of direction takes place each time the button is released and pressed again.

When the butterfly valve has reached its final position, the dots disappear.

4.8.1 Operating time in Manual mode

Parameter 16

Determines whether the BCU in Manual mode is reset to the standby position for Manual mode.

Parameter 16 = 0: Manual mode is not limited in time.

If this function has been selected, operation of the burner may be continued manually in the event of failure of the control system or the bus.

Parameter 16 = 1: five minutes after the last time the button is pressed, the BCU ends burner operation and moves abruptly back to the standby position for Manual mode. The burner can be restarted manually.

Manual mode is terminated by switching off the BCU or in the event of a power failure.

4.9 Fault messages

4.9.1 The last 10 fault messages

Parameters 81 – 90

The BCU shows the last 10 fault messages.

In order to analyze a burner system, the last fault messages can be called up in the order in which they occurred. Extended diagnostics is possible using the BCSoft software.

The BCU records the last 10 fault messages internally. Parameter 81 shows the most recent fault message, parameter 82 the one before and so on.

4.10 Password

4.10.1 User-defined password

Parameter 30

Password saved to protect parameter settings.

To prevent unauthorized changes to parameter settings, a password is stored in parameter 30. The parameter settings can be modified after the password (4 numbers) has been entered. The password can be changed using BCSoft. Note the effect of parameter settings on the safe functioning of your system.

The password set at the factory can be found in the delivery note supplied.

5 Selection

BCU 370: for modulating-controlled forced draught burners

	W	Q	I1	I2	I3	F	E	U0	U1	D1	D3	B1*	-3*
BCU 370	●	●	●	○	○	●	●	●	○	●	○	○	○

● = standard, ○ = available

* If "none", this specification is omitted.

Order example

BCU 370W11FEU0D1

5.1 Type code

Code	Description
BCU	Burner control unit
W	Mains voltage
Q	230 V AC, 50/60 Hz 120 V AC, 50/60 Hz
I1	Ignition
I2*	Electronic ignition, single-pole
I3*	Electronic ignition, double-pole
no specification	Electronic ignition, double-pole with neutral conductor Without ignition
F	Fan control
E	Valve control
U0	Flame control
U1	Ionization control (continuous or intermittent op.) or UV control (intermittent op. with UVS) UV (continuous operation with UVD 1)
D1	DG _{max.} monitoring
D3	Integrated tightness control
B1	For PROFIBUS DP
-3	Three-point step control via PROFIBUS DP

* I2 only for 230 V, I3 only for 120 V

Please quote the required settings of all parameters when ordering, see "Parameters".

6 Project planning information

6.1 Cable selection

Use mains cable suitable for the type of operation and complying with local regulations.

Signal and control line: max. 1.5 mm².

Control line for UVC 1 wiring: 1 mm².

Cable for burner ground: 4 mm².

Do not route BCU cables in the same cable duct as frequency converter cables or cables emitting strong fields.

6.1.1 Ionization cable

Use an unscreened high voltage cable for the ignition cable, see page 71 (Accessories).

Recommended cable length: max. 50 m (164 ft).

Lay cables individually, not in a metal conduit.

Install well away from mains cables and interference from electro-magnetic sources.

Do not lay together with ignition cable.

6.1.2 UV cable

Cable length: max. 50 m (164 ft).

Install well away from mains cables and interference from electro-magnetic sources.

Do not lay together with ignition cable.

6.1.3 Ignition cable

(BCU 370..I1, BCU 370..I2 with integrated electronic ignition unit)

Use an unscreened high voltage cable, see page 71 (Accessories).

Cable length: max. 1 m (3.2 ft).

Avoid external electrical interference.

Permanently connect the ignition cable(s) to the integrated ignition unit using plug connectors, see page 71 (Accessories).

Lay cables individually, not in a metal conduit.

Do not lay UV/ionization cable and ignition cable(s) together and lay them as far apart as possible.

Feed out of the BCU on the shortest possible route (no loops). Push through corresponding knock-out hole(s) in the housing and use enclosed M16 cable gland(s).

Only use radio interference suppressed terminal boots (with 1 k Ω resistor), see page 71 (Accessories).

For units with external ignition, e.g. ignition transformer TGI, please note the corresponding unit instructions.

6.2 Fan control

The BCU features an output for fan control. The max. start-up current for the fan motor must not exceed the permitted contact rating of this output, see page 73 (Technical data). If necessary, an external contactor must be used.

6.3 Controlling the butterfly valve

The required burner commissioning time depends on the running time of the butterfly valve actuator.

The BCU 370 waits for the feedback signal to indicate that the actuator has reached the Open position, for instance, before the pre-purge time is started.

The Ignition position is always approached via the Open position.

Once the butterfly valve has been set to the relevant position, a plausibility check takes place. The related control output is switched off briefly. The feedback signal must drop accordingly.

6.4 Safety interlock (limits)

The limiters in the safety interlock (linking of all the relevant safety control and switching equipment for the use of the application, for example STL [safety temperature limiter]) must isolate terminal 24 from the voltage supply. If the safety interlock is interrupted, the display shows a blinking **50** as a warning signal. The program sequence is interrupted. All of the BCU 370's outputs are disconnected from the electrical power supply. The burner control unit restarts when the safety interlock is switched on again and the start-up signal (\varnothing) activated.

6.5 Too many remote resets

If a remote reset is made 5 times in 15 minutes (terminal 23 or by bus signal), the BCU is locked, shows fault message **10**, "Too many remote resets", and can only be reset by pressing the Reset/Information button.

6.6 Protecting the ignition unit from overload

The BCU protects the integrated ignition unit and the electronic switch from overload. Excessive switching triggers a warning signal (blinking ). After the minimum cycle time has elapsed, the BCU starts.

The minimum cycle time saved in the BCU can be calculated using the formula:

$$\text{Minimum cycle time} = (t_{VZ} + t_{SA1} - 1) \times 6$$

Example:

Pre-ignition time $t_{VZ} = 2 \text{ s}$,

1st safety time on start-up $t_{SA1} = 3 \text{ s}$

$$(2 \text{ s} + 3 \text{ s} - 1) \times 6 = 24 \text{ s}$$

In this example, the BCU 370 may not be started more often than every 24 s.

If an external ignition unit/transformer is being used, the formula is as follows:

$$\text{Minimum cycle time} = (t_{VZ} + t_{SA1} - 1) \times 2$$

Adjust the minimum burner pause time t_{PB} (parameter 11) correspondingly, if required.

6.7 Wiring

The BCU is suitable for hard wiring only. Do not reverse phase and neutral conductor. Different phases of a three-phase current system must not be installed at the inputs. Do not connect voltage to the outputs.

On BCU 370..B1 for PROFIBUS DP, no voltage may be connected to terminals 17 to 23. Otherwise, the BCU may be damaged.

6.7.1 Single-electrode operation with external ignition unit

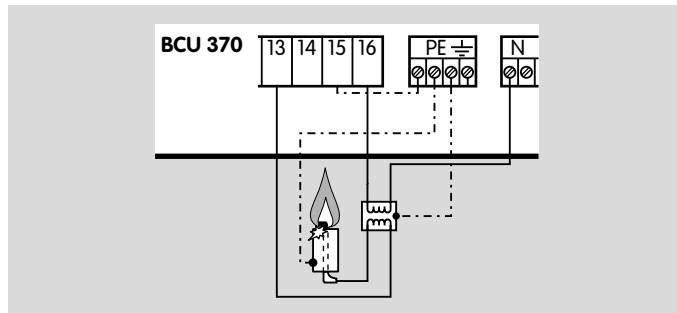

If a burner only has one electrode, which is used for ignition and ionization control, an external ignition transformer must be used, e.g. TZI or TGI.

6.8 BCU switched off

The BCU indicates . In general, it cannot be activated when no mains voltage is applied or the burner control unit is switched off. The fault signalling contact is only closed when the BCU is supplied with voltage and switched on.

BCU 370..B1

The bus interface is still operational to maintain the function of the communications system. The control outputs of the BCU (valves, ignition unit) are electrically isolated from the mains voltage.

6.9 Note on EC type-examination or CSA and FM approval

Since EN 298 (1993) or NFPA 85 and NFPA 86 does not describe all functions of the BCU 370, the operator is responsible for ensuring that all parameters and functions are matched to the respective application.

6.10 Contact fuses

The safety-related switching contacts on the BCU 370 (V1, V2, V3, Ignition, Controller enable, Open butterfly valve, Close butterfly valve and Butterfly valve ignition) are protected by an internal fuse (3.15 A, slow-acting). This fuse cannot be replaced, since safe opening of the contacts is not guaranteed following overload or a short-circuit, e.g. due to a wiring fault. The BCU must be returned to the manufacturer for repair.

6.11 Installation

Recommended installation position: vertical (cable glands pointing downwards).

Detach the upper section of the BCU, remove and screw on lower section with four screws \varnothing 4 mm. Replace upper section and screw into place.

6.12 Protective circuits

Connected control elements must be equipped with protective circuits in accordance with the manufacturer's instructions. This prevents high voltage peaks which can cause malfunction of the BCU.

6.13 BCSoft

Changes using BCSoft must be verified by scanning the parameters using the Reset/Information button.

7 Flame control ...

7.1 ...with flame rod

The BCU generates an alternating voltage (230 V AC) between the sensing electrode and burner ground. The flame rectifies this voltage. Only the DC signal ($> 1 \mu\text{A}$) is detected by the burner control unit.

A flame cannot be simulated.

Ignition and monitoring with a single electrode are possible if an external ignition transformer is used.

The requirements for continuous operation are satisfied in the event of flame control using a flame rod.

7.2 ...with UV sensor

A UV tube inside the UV sensor detects the ultraviolet light of a flame. It does not respond to sunlight, incandescent bulb light or infrared radiation emitted by hot workpieces or red-hot furnace walls.

In the event of incident UV radiation, the UV sensor rectifies the supplied alternating voltage. As with ionization control, the burner control unit only detects this DC signal.

When using UV sensors of Type UVS, the burner control unit may be used for intermittent operation only. This means that operation must be interrupted at least once every 24 hours. This can be programmed using parameter 17 = 1.

Further information can be found in Technical Information bulletins UVS 5 and UVS 10 at www.docuthek.com.

The burner control unit BCU..U1 is prepared for UV flame detector UVC 1. This enables continuous operation.

Further information can be found in TI UVC at www.docuthek.com.

8 Accessories

8.1 High-voltage cable

FZLSi 1/7 up to 180°C (356°F),

Order No.: 04250410,

FZLK 1/7 up to 80°C (176°F),

Order No.: 04250409.

8.2 BCSoft

The current software can be downloaded from our Internet site at www.docuthek.com. To do so, you need to register in the DOCUTHEK.

8.2.1 Opto-adaptor PCO 200



BCSoft CD-ROM included,

Order No.: 74960625.

8.3 Radio interference suppressed terminal boots

Right-angle terminal boot, 4 mm, interference-suppressed,

Order No.: 04115308.

Straight terminal boot, 4 mm, interference-suppressed,

Order No.: 04115307.

Straight terminal boot, 6 mm, interference-suppressed,

Order No.: 04115306.

8.4 Connection kit BCU 370

2 M16 cables glands,

2 plug connectors for ignition cable,

2 seal inserts for M20 cable glands.

The connection kit is included in the scope of delivery for the lower section.

Order No.: 74960479

8.5 Set of stickers BCU 370

Various stickers with information in the following languages: D, F, I, NL and E,

sticker: "Important, changed parameters".

The set of stickers is included in the scope of delivery for the upper section.

Order No.: 74960480

8.6 GSD master data file for BCU 370..B1

The GSD file can be downloaded from our Internet site at www.docuthek.com.

Log on to the Docuthek and then choose document type “Software”.

GSD file on CD,

Order No.: 74960460.

9 Technical data

Mains voltage:

BCU..W: 230 V AC, -15/+10%, 50/60 Hz, or

BCU..Q: 120 V AC, -15/+10%, 50/60 Hz,

for grounded or ungrounded mains.

Flame control with UV sensor or flame rod.

Flame signal for:

Ionization control: 1 – 28 µA,

UV control: 1 – 35 µA.

For intermittent or continuous operation.

Air pressure check during pre-purge and operation by external air pressure switch DL.

Maximum length of ignition cable with integrated electronic ignition: 1 m (3.2 ft).

Electronic ignitions:

BCU 370W..I1:

Ignition voltage: 22 kVpp,

ignition current: 40 mA,

spark gap: 3 mm,

secondary connection diameter: 1 × 4 mm

to grounding connection.

BCU 370W..I2:

Ignition voltage: 22 kVpp,

ignition current: 40 mA,

spark gap: 3 mm,

secondary connection diameter: 2 × 4 mm.

BCU 370Q..I1:

Ignition voltage: 12 kV amplitude,

ignition current: 40 mA,

spark gap: 3 mm,

secondary connection diameter: 1 × 4 mm

to grounding connection.

BCU 370Q..I3:

Ignition voltage: 2 × 6.5 kV amplitude,

ignition current: 40 mA,

spark gap: 3 mm,

secondary connection diameter: 2 × 4 mm

plug to grounding connection.

Maximum length of ionization/UV cable: 50 m (164 ft).

Max. number of operating cycles: 250,000.

Ambient temperature:

BCU 370: -20 to +60°C (-4 to +140°F),

BCU 370..I: -10 to +60°C (14 to 140°F),

no condensation permitted.

Enclosure: IP 54 pursuant to IEC 529.

Permitted operating altitude: < 2000 m AMSL.



Technical data

Housing made of impact-resistant and heat-resistant plastic. Plug-in upper section with operating controls and indicators.

Lower section with connection terminals, grounding strip and pre-wired neutral bus with spacious wiring chamber.

1x M25 multiple cable gland, 4x 7 mm cable grommets, 2x M20 multiple cable gland, 2x 7 mm cable grommets, and loosely enclosed

1x or 2x M16 plastic cable gland(s) for the ignition cable(s).

Voltage to inputs, valves, fan, controller enable, actuator and ignition unit = mains voltage.

Power consumption: approx. 9 VA plus approx. 50 VA for integrated ignition.

Input voltage of signal inputs:

Rated value	120 V AC	230 V AC
Signal "1"	80 - 126.5 V	160 - 253 V
Signal "0"	0 - 20 V	0 - 40 V

Input current signal "1": typ. 2 mA

Output to ignition transformer:

no-switch contacts via semi-conductor.

Contact rating:

Valves: max. 1 A, $\cos \varphi = 1$,

Butterfly valves: max. 1 A, $\cos \varphi = 1$,

Ignition: max. 1 A, $\cos \varphi = 0.3$,

Controller enable signal: max. 1 A, $\cos \varphi = 1$,

the contacts may be loaded with a max. total of 2.5 A,
Fan: max. 3 A, start-up current: max. 6.5 A < 1 s.

The outputs may be loaded with a max. total of 4 A.

Operation and fault signalling contacts:

Dry contact, max. 1 A, 253 V, not internally fused (does not satisfy the requirements for safe isolation, therefore not floating).

Reset/Information button: max. number of operating cycles: 1000.

Fuse in BCU, replaceable, F1: T 5A H, pursuant to IEC 60127-2/5.

Fuse for protecting the safety-relevant outputs V1, V2, V3, Ignition, Controller enable, Open valve, Close valve and Valve ignition position: 3.15 A, slow-acting, not replaceable.

Permissible UV sensors:

Honeywell Kromschroder models UVS 1, 5, 10 and UVC 1.

Weight: approx. 1.8 kg.

9.1 PROFIBUS DP

Manufacturer ID: 0x08EC.

ASIC type: SPC3.

SYNC- and FREEZE-capable.

Baud rate detection: automatic.

Min. cycle time: 0.1 ms.

Diagnostic bytes: 6 (DP Standard).

Parameter bytes: 7 (DP Standard).

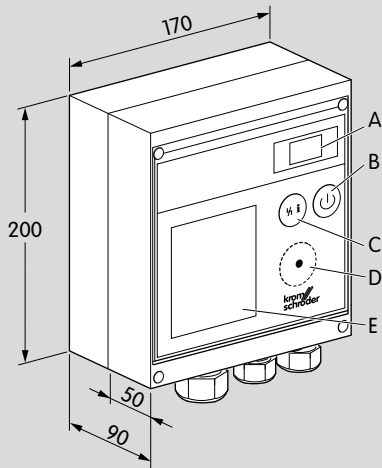

9.2 Operating controls and dimensions



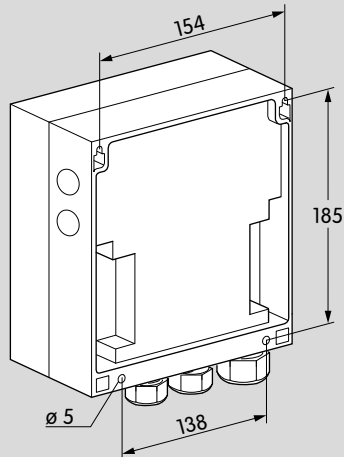















- A: 2-digit 7-segment display
 - B: Off switch, deactivates the BCU, outputs are disconnected from the electrical power supply
 - C: Reset/Information button to reset the system after a fault, to scan parameters on the display or to control manual operation
 - D: Optical interface
 - E: BCU label with the most important status messages in English
- Additional stickers in D, F, I, NL and E enclosed



9.3 Converting units

See www.adlatus.org

10 Legend

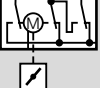
	Display
	Blinking display
	Ready
	Safety interlocks (limits)
	Start-up signal
	Controlled air flow
	Ignition transformer
	Gas valve
	Flame signal
	Operating signal
	Fault signal
	Reset
	Input signal
	Output signal
	Flame simulation check
	Pressure switch (DL for air, DG for gas)
	Ignition/Ignition position
	Three-point step controller
	Actuator (in connection diagram)

11 Glossary

11.1 Safety shut-down

The burner control unit performs a safety shut-down immediately after receiving a signal from a safety device or after a fault is detected (e.g. flame or air pressure failure). The safety shut-down prevents operation of the burner by closing the fuel shut-off valves and deactivating the ignition device.

For this, the BCU disconnects the gas valves and the ignition transformer from the electrical power supply. The operation signalling contact and the controller enable signal are deactivated. The fault signalling contact remains open. The display blinks and displays the current program step, see page 37 (Fault message (blinking)).

After a safety shut-down, the BCU can restart automatically.

11.2 Fault lock-out

A fault lock-out is a safety shut-down with subsequent lock-out. The system can only be restarted following manual reset. The protective system cannot be reset by mains failure.

In the event of a fault lock-out of the BCU, the fault signalling contact closes, the display blinks and shows the current program step, see page 37 (Fault message (blinking)). The gas valves are disconnected from

the electrical power supply. The fault signalling contact opens if the mains voltage fails.

In order to restart, the BCU can only be reset manually using the button on the front panel, the OCU or the remote reset input (terminal 3).

11.3 Warning signal

The BCU reacts to operating faults, e.g. in the case of permanent remote resets, with a warning signal. The display blinks and shows the corresponding warning message. The warning signal ends once the cause has been eliminated.

The program sequence continues. No fault signal is activated.

11.4 Timeout 25 s/250 s

For some process faults, a timeout phase elapses before the BCU reacts to the fault. The phase starts as soon as the BCU detects the process fault and ends after 25 to 250 s. A safety shut-down or fault lock-out is then performed. If the process fault ends during the timeout phase, the process continues as before.

12 Annex

12.1 Status and fault messages for PROFIBUS DP

This table can be used to program the master.

Input bytes (BCU → master)		
Byte 2	Byte 0, Bit 2 = 0 (Status message)	Byte 0, Bit 2 = 1 (Fault message)
0	0 Start-up position/standby	
1	A0 Valve moves to Closed position	01 Flame simulation
2	01 Fan run up time	
3	A1 Butterfly valve moves to Open position	
4	P1 Pre-purge time	04 Start-up without flame signal
5	A2 Butterfly valve moves to Ignition position	05 Flame failure during 1 st flame proving period
6	03 Pre-ignition time	06 Flame failure during 2 nd safety time
7	04 1 st safety time on start-up	07 Flame failure during 2 nd flame proving period
8	05 1 st flame proving period	08 Flame failure during operation
9	06 2 nd safety time on start-up	
10	07 2 nd flame proving period	d0 Fault Air monitor break contact check
11	08 Controller enable signal	d1 Fault Air monitor make contact check
12	P9 Post-purge time	d2 Fault Air supply while butterfly valve moves to Ignition position
13		d3 Fault Air supply during pre-ignition time
14		d4 Fault Air supply during 1 st safety time on start-up
15		d5 Fault Air supply during 1 st flame proving period
16		d6 Fault Air supply during 2 nd safety time on start-up
17		d7 Fault Air supply during 2 nd flame proving period
18		d8 Fault Air supply during operation
19		dP Fault Air supply during pre-purge time



Input bytes (BCU → master)		
Byte 2	Byte 0, Bit 2 = 0 (Status message)	Byte 0, Bit 2 = 1 (Fault message)
20	u0 Fault DG _{min} during standby	
21	u1 Fault DG _{min} while butterfly valve moves to Open position	
22	u2 Fault DG _{min} while butterfly valve moves to Closed position	
23	u3 Fault DG _{min} during pre-ignition time	
24	u4 Fault DG _{min} during 1 st safety time on start-up	
25	u5 Fault DG _{min} during 1 st flame proving period	
26	u6 Fault DG _{min} during 2 nd safety time	
27	u7 Fault DG _{min} during 2 nd flame proving period	
28	u8 Fault DG _{min} during operation	
29	u9 Fault DG _{min} during post-purge time	
30		o0 Fault DG _{max} in start-up position/standby
31		o1 Fault DG _{max} while butterfly valve moves to Open position
32		o2 Fault DG _{max} while butterfly valve moves to Closed position
33		o3 Fault DG _{max} during pre-ignition time
34		o4 Fault DG _{max} during 1 st safety time during operation
35		o5 Fault DG _{max} during 1 st flame proving period
36		o6 Fault DG _{max} during 2 nd safety time during operation
37		o7 Fault DG _{max} during 2 nd flame proving period
38		o8 Fault DG _{max} during operation



Input bytes (BCU → master)		
Byte 2	Byte 0, Bit 2 = 0 (Status message)	Byte 0, Bit 2 = 1 (Fault message)
39		o9 Fault DG _{max} during post-purge time
40		A0 Butterfly valve closed position not reached
41		A1 Butterfly valve open position not reached
42		A2 Butterfly valve ignition position not reached
50		10 Too many remote resets
58		bE Bus module error
61		31 CRC error: Parameter
62	32 Undervoltage	
63		33 EEPROM parameter exceeds limit valve
65		35 Fault Valve feedback
66		36 Tightness control: V1 leaking
67		37 Tightness control: V2/V3 leaking
80	50 Safety interlock failure	
82	52 Permanent remote reset	
83	53 Timing cycle too short	
85	55 DG _{min} oscillating	
86	56 Open + Close set simultaneously	
99	99 Internal error	
100	H0 Switch-on delay time/pause time	
104	C1 Controlled air flow	
108	H8 Controller enable signal delay time	

Feedback

Finally, we are offering you the opportunity to assess this “Technical Information (TI)” and to give us your opinion, so that we can improve our documents further and suit them to your needs.

Clarity

Found information quickly
Searched for a long time
Didn't find information
What is missing?
No answer

Comprehension

Coherent
Too complicated
No answer

Scope

Too little
Sufficient
Too wide
No answer



Use

To get to know the product
To choose a product
Planning
To look for information

Navigation

I can find my way around
I got “lost”
No answer

My scope of functions

Technical department
Sales
No answer

Remarks

Contact

Elster GmbH
Postfach 2809 · 49018 Osnabrück
Strothweg 1 · 49504 Lotte (Büren)
Germany

Tel. +49 541 1214-0
Fax +49 541 1214-370
hts.lotte@honeywell.com
www.kromschroeder.com

The current addresses of our international agents are available on the Internet:
<https://thermalsolutions.honeywell.com> →
contact us

We reserve the right to make technical modifications in the interests of progress.
Copyright © 2019 Elster GmbH
All rights reserved.

